

**64M-bit Synchronous DRAM, 133MHz
4-bank, LVTTL****Description**

The μ PD4564441-A75, 4564841-A75, 4564163-A75 are high-speed 67,108,864-bit synchronous dynamic random-access memories, organized as 4,194,304 \times 4 \times 4, 2,097,152 \times 8 \times 4, 1,048,576 \times 16 \times 4 (word \times bit \times bank), respectively.

The synchronous DRAMs achieved high-speed data transfer using the pipeline architecture.

All inputs and outputs are synchronized with the positive edge of the clock.

The synchronous DRAMs are compatible with Low Voltage TTL (LVTTL).

These products are packaged in 54-pin plastic TSOP (II).

Features

- Fully Synchronous Dynamic RAM, with all signals referenced to a positive clock edge
- Pulsed interface
- Possible to assert random column address in every cycle
- Quad internal banks controlled by A12 and A13 (Bank Select)
- Byte control (\times 16) by LDQM and UDQM
- Programmable Wrap sequence (Sequential / Interleave)
- Programmable burst length (1, 2, 4, 8 and full page)
- /CAS latency (3)
- Automatic precharge and controlled precharge
- CBR (auto) refresh and self refresh
- \times 4, \times 8, \times 16 organization
- Single 3.3 V \pm 0.3 V power supply
- LVTTL compatible inputs and outputs
- 4,096 refresh cycles / 64 ms
- Burst termination by Burst stop command and Precharge command

Ordering Information

Part number	Organization (word \times bit \times bank)	Clock frequency MHz (MAX.)	Package
μ PD4564441G5-A75-9JF	4M \times 4 \times 4	133	54-pin Plastic TSOP (II) (10.16mm (400))
μ PD4564841G5-A75-9JF	2M \times 8 \times 4		
μ PD4564163G5-A75-9JF	1M \times 16 \times 4		

The information in this document is subject to change without notice. Before using this document, please confirm that this is the latest version.

Not all devices/types available in every country. Please check with local Elpida Memory, Inc. for availability and additional information.

Part Number

[x4, x8]

μPD4564841G5 - A75

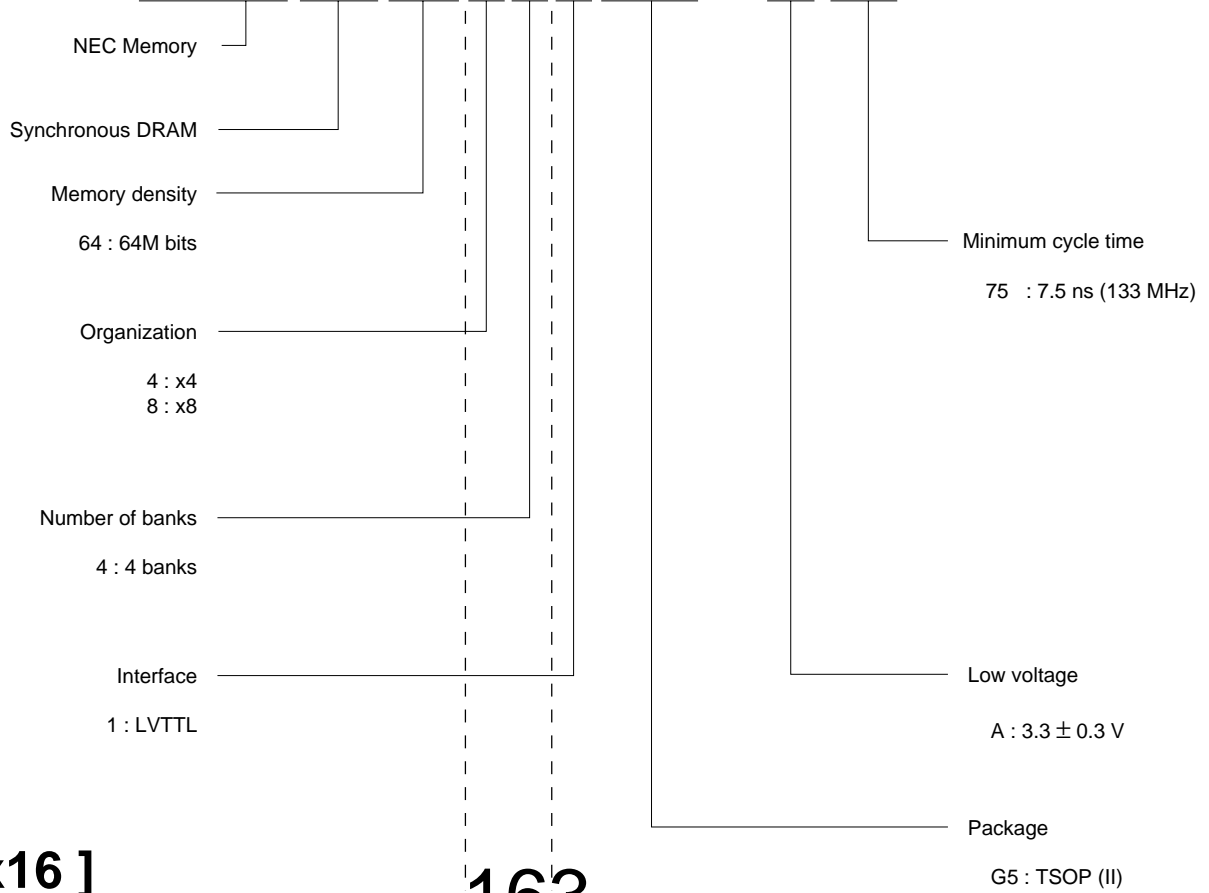

[x16]

163

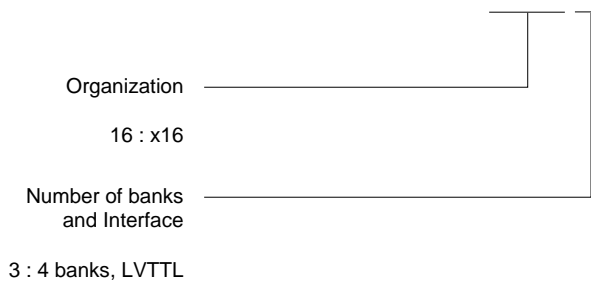

Pin Configurations

/xxx indicates active low signal.

[μPD4564441-A75]
54-pin Plastic TSOP (II) (10.16mm (400))
4M words × 4 bits × 4 banks

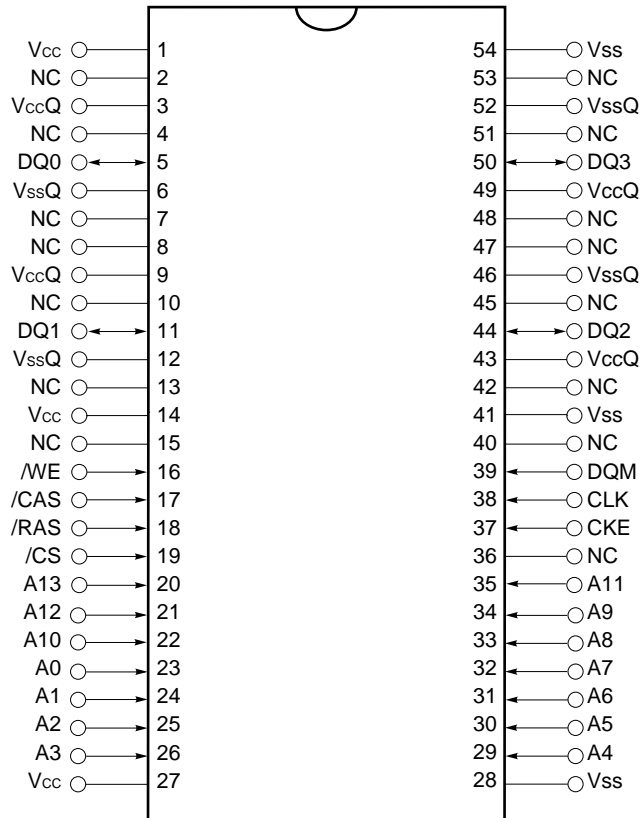

- A0 to A13 ^{Note} : Address inputs
- DQ0 to DQ3 : Data inputs / outputs
- CLK : Clock input
- CKE : Clock enable
- /CS : Chip select
- /RAS : Row address strobe
- /CAS : Column address strobe
- /WE : Write enable
- DQM : DQ mask enable
- Vcc : Supply voltage
- Vss : Ground
- VccQ : Supply voltage for DQ
- VssQ : Ground for DQ
- NC : No connection

- Note** A0 to A11 : Row address inputs
- A0 to A9 : Column address inputs
- A12, A13 : Bank select

[μPD4564841-A75]
 54-pin Plastic TSOP (II) (10.16mm (400))
 2M words × 8 bits × 4 banks

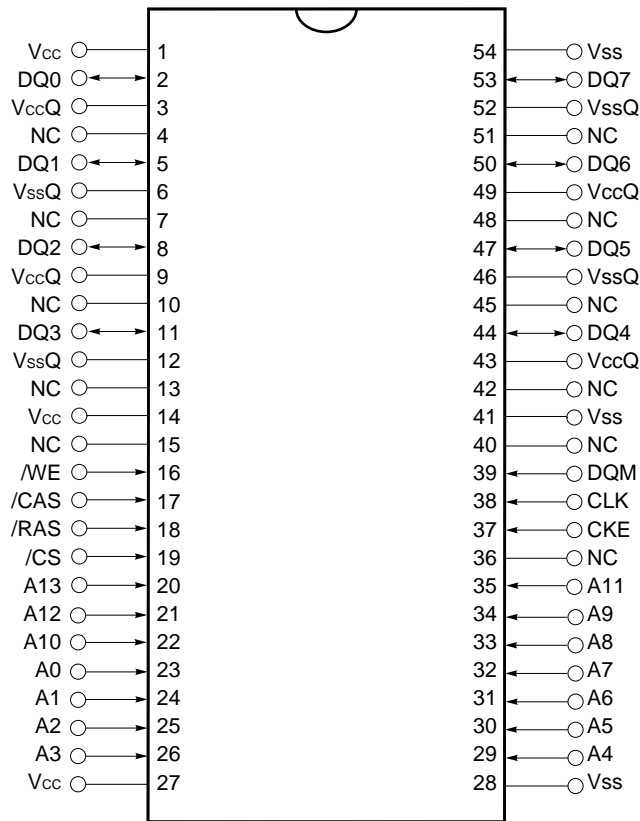

- A0 to A13 ^{Note}: Address inputs
- DQ0 to DQ7 : Data inputs / outputs
- CLK : Clock input
- CKE : Clock enable
- /CS : Chip select
- /RAS : Row address strobe
- /CAS : Column address strobe
- /WE : Write enable
- DQM : DQ mask enable
- Vcc : Supply voltage
- Vss : Ground
- VccQ : Supply voltage for DQ
- VssQ : Ground for DQ
- NC : No connection

- Note** A0 to A11 : Row address inputs
- A0 to A8 : Column address inputs
- A12, A13 : Bank select

[μPD4564163-A75]
 54-pin Plastic TSOP (II) (10.16mm (400))
 1M words × 16 bits × 4 banks

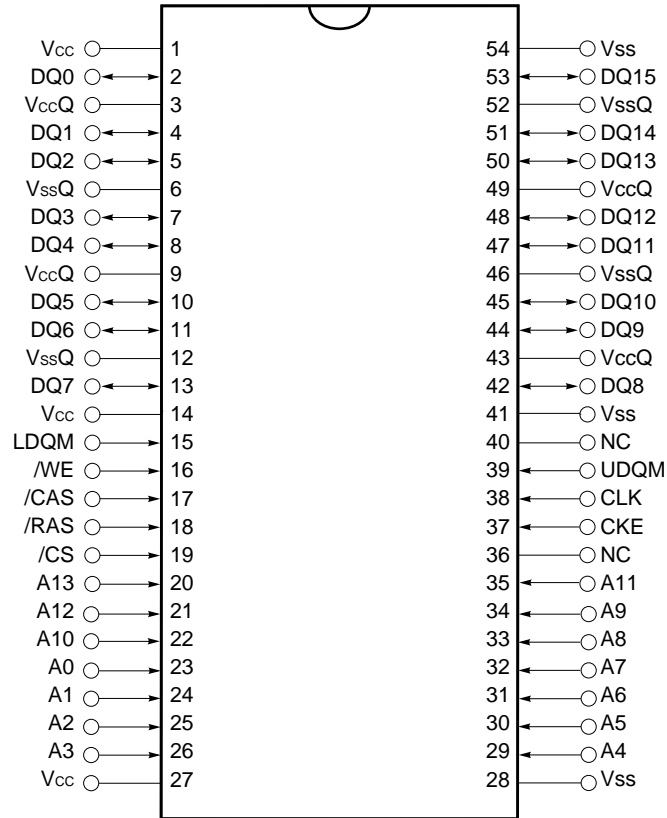

A0 to A13 ^{Note} : Address inputs

DQ0 to DQ15 : Data inputs / outputs

CLK : Clock input

CKE : Clock enable

/CS : Chip select

/RAS : Row address strobe

/CAS : Column address strobe

/WE : Write enable

LDQM : Lower DQ mask enable

UDQM : Upper DQ mask enable

Vcc : Supply voltage

Vss : Ground

VccQ : Supply voltage for DQ

VssQ : Ground for DQ

NC : No connection

Note A0 to A11 : Row address inputs

A0 to A7 : Column address inputs

A12, A13 : Bank select

Block Diagram

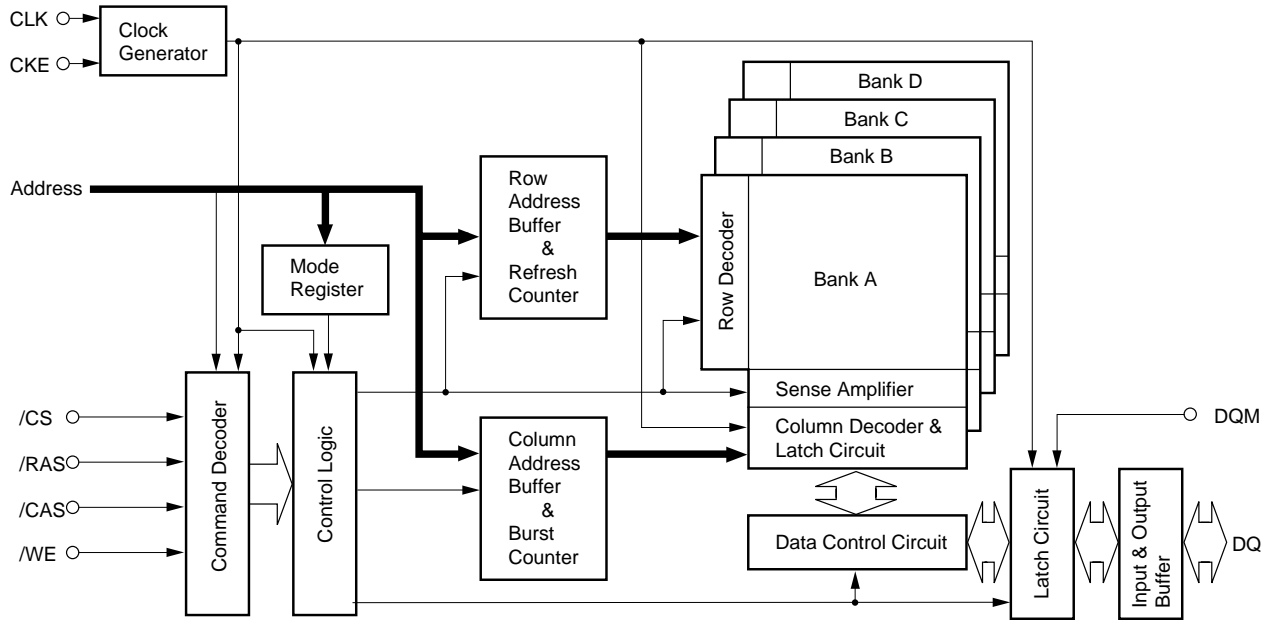

CONTENTS

1. Input / Output Pin Function	9
2. Commands	10
3. Simplified State Diagram	13
4. Truth Table	14
4.1 Command Truth Table	14
4.2 DQM Truth Table	14
4.3 CKE Truth Table	14
4.4 Operative Command Table	15
4.5 Command Truth Table for CKE	18
5. Initialization	19
6. Programming the Mode Register	20
7. Mode Register	21
7.1 Burst Length and Sequence	22
8. Address Bits of Bank-Select and Precharge	23
9. Precharge	24
10. Auto Precharge	25
10.1 Read with Auto Precharge	25
10.2 Write with Auto Precharge	26
11. Read / Write Command Interval	27
11.1 Read to Read Command Interval	27
11.2 Write to Write Command Interval	27
11.3 Write to Read Command Interval	28
11.4 Read to Write Command Interval	29
12. Burst Termination	30
12.1 Burst Stop Command	30
12.2 Precharge Termination	31
12.2.1 Precharge Termination in READ Cycle	31
12.2.2 Precharge Termination in WRITE Cycle	32

13. Electrical Specifications	33
13.1 AC Parameters for Read Timing	38
13.2 AC Parameters for Write Timing	40
13.3 Relationship between Frequency and Latency	41
13.4 Mode Register Set	42
13.5 Power On Sequence and CBR (Auto) Refresh	43
13.6 /CS Function	44
13.7 Clock Suspension during Burst Read (using CKE Function)	45
13.8 Clock Suspension during Burst Write (using CKE Function)	46
13.9 Power Down Mode and Clock Mask	47
13.10 CBR (Auto) Refresh	48
13.11 Self Refresh (Entry and Exit)	49
13.12 Random Column Read (Page with Same Bank)	50
13.13 Random Column Write (Page with Same Bank)	51
13.14 Random Row Read (Ping-Pong Banks)	52
13.15 Random Row Write (Ping-Pong Banks)	53
13.16 Read and Write	54
13.17 Interleaved Column Read Cycle	55
13.18 Interleaved Column Write Cycle	56
13.19 Auto Precharge after Read Burst	57
13.20 Auto Precharge after Write Burst	58
13.21 Full Page Read Cycle	59
13.22 Full Page Write Cycle	60
13.23 Byte Write Operation	61
13.24 Burst Read and Single Write (Option)	62
13.25 Full Page Random Column Read	63
13.26 Full Page Random Column Write	64
13.27 PRE (Precharge) Termination of Burst	65
14. Package Drawing	66
15. Recommended Soldering Condition	67
16. Revision History	68

1. Input / Output Pin Function

Pin name	Input / Output	Function
CLK	Input	CLK is the master clock input. Other inputs signals are referenced to the CLK rising edge.
CKE	Input	CKE determine validity of the next CLK (clock). If CKE is high, the next CLK rising edge is valid; otherwise it is invalid. If the CLK rising edge is invalid, the internal clock is not issued and the μ PD4564xxx suspends operation. When the μ PD4564xxx is not in burst mode and CKE is negated, the device enters power down mode. During power down mode, CKE must remain low.
/CS	Input	/CS low starts the command input cycle. When /CS is high, commands are ignored but operations continue.
/RAS, /CAS, /WE	Input	/RAS, /CAS and /WE have the same symbols on conventional DRAM but different functions. For details, refer to the command table.
A0 - A13	Input	Row Address is determined by A0 - A13 at the CLK (clock) rising edge in the active command cycle. It does not depend on the bit organization. Column Address is determined by A0 - A9 at the CLK rising edge in the read or write command cycle. It depends on the bit organization: A0 - A9 for $\times 4$ device, A0 - A8 for $\times 8$ device, A0 - A7 for $\times 16$ device. A12 and A13 are the bank select signal (BS). In command cycle, A12 and A13 low select bank A, A12 low and A13 high select bank B, A12 high and A13 low select bank C and then A12 and A13 high select bank D. A10 defines the precharge mode. When A10 is high in the precharge command cycle, all banks are precharged; when A10 is low, only the bank selected by A12 and A13 is precharged. When A10 is high in read or write command cycle, the precharge starts automatically after the burst access.
DQM, UDQM, LDQM	Input	DQM controls I/O buffers. In $\times 16$ products, UDQM and LDQM control upper byte and lower byte I/O buffers, respectively. In read mode, DQM controls the output buffers like a conventional /OE pin. DQM high and DQM low turn the output buffers off and on, respectively. The DQM latency for the read is two clocks. In write mode, DQM controls the word mask. Input data is written to the memory cell if DQM is low but not if DQM is high. The DQM latency for the write is zero.
DQ0 - DQ15	Input / Output	DQ pins have the same function as I/O pins on a conventional DRAM.
V _{cc} , V _{ss} , V _{ccQ} , V _{ssQ}	(Power supply)	V _{cc} and V _{ss} are power supply pins for internal circuits. V _{ccQ} and V _{ssQ} are power supply pins for the output buffers.

2. Commands

Mode register set command

(/CS, /RAS, /CAS, /WE = Low)

The μPD4564xxx has a mode register that defines how the device operates. In this command, A0 through A13 are the data input pins. After power on, the mode register set command must be executed to initialize the device.

The mode register can be set only when all banks are in idle state.

During 2 CLK (t_{TRSC}) following this command, the μPD4564xxx cannot accept any other commands.

Fig.1 Mode register set command

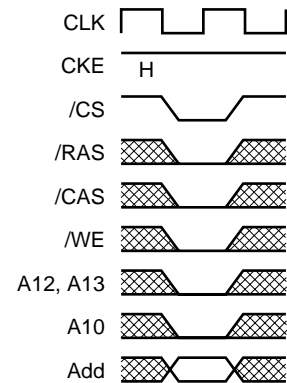

Activate command

(/CS, /RAS = Low, /CAS, /WE = High)

The μPD4564xxx has four banks, each with 4,096 rows.

This command activates the bank selected by A12 and A13 (BS) and a row address selected by A0 through A11.

This command corresponds to a conventional DRAM's /RAS falling.

Fig.2 Row address strobe and bank activate command

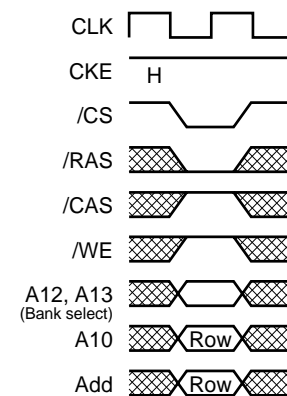

Precharge command

(/CS, /RAS, /WE = Low, /CAS = High)

This command begins precharge operation of the bank selected by A12 and A13 (BS). When A10 is High, all banks are precharged, regardless of A12 and A13. When A10 is Low, only the bank selected by A12 and A13 is precharged.

After this command, the μPD4564xxx can't accept the activate command to the precharging bank during t_{RP} (precharge to activate command period).

This command corresponds to a conventional DRAM's /RAS rising.

Fig.3 Precharge command

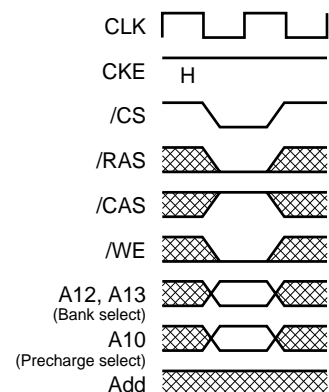

Write command

(/CS, /CAS, /WE = Low, /RAS = High)

If the mode register is in the burst write mode, this command sets the burst start address given by the column address to begin the burst write operation. The first write data in burst mode can input with this command with subsequent data on following clocks.

Fig.4 Column address and write command

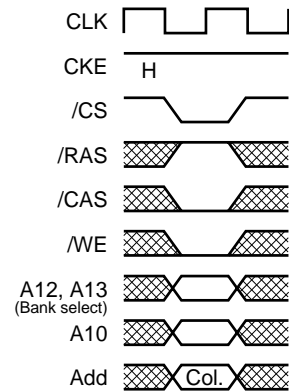

Read command

(/CS, /CAS = Low, /RAS, /WE = High)

Read data is available after /CAS latency requirements have been met. This command sets the burst start address given by the column address.

Fig.5 Column address and read command

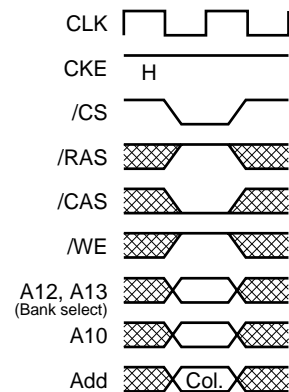

CBR (auto) refresh command

(/CS, /RAS, /CAS = Low, /WE, CKE = High)

This command is a request to begin the CBR (auto) refresh operation. The refresh address is generated internally.

Before executing CBR (auto) refresh, all banks must be precharged.

After this cycle, all banks will be in the idle (precharged) state and ready for a row activate command.

During t_{RC} period (from refresh command to refresh or activate command), the μPD4564xxx cannot accept any other command.

Fig.6 CBR (auto) refresh command

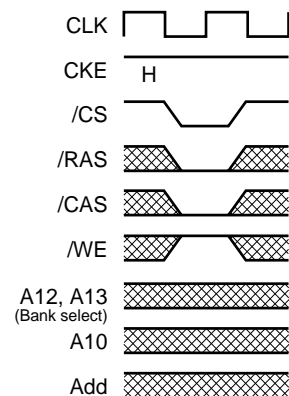

Self refresh entry command

(/CS, /RAS, /CAS, CKE = Low, /WE = High)

After the command execution, self refresh operation continues while CKE remains low. When CKE goes high, the μPD4564xxx exits the self refresh mode.

During self refresh mode, refresh interval and refresh operation are performed internally, so there is no need for external control.

Before executing self refresh, all banks must be precharged.

Fig.7 Self refresh entry command

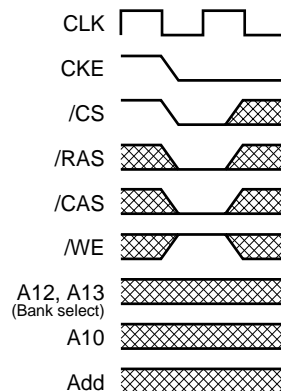

Burst stop command

(/CS, /WE = Low, /RAS, /CAS = High)

This command can stop the current burst operation.

Fig.8 Burst stop command in Full Page Mode

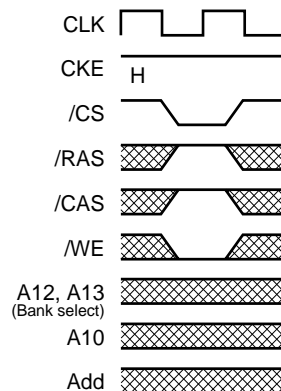

No operation

(/CS = Low, /RAS, /CAS, /WE = High)

This command is not an execution command. No operations begin or terminate by this command.

Fig.9 No operation

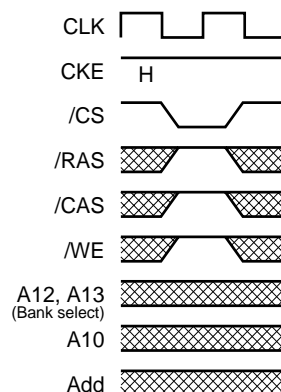

3. Simplified State Diagram

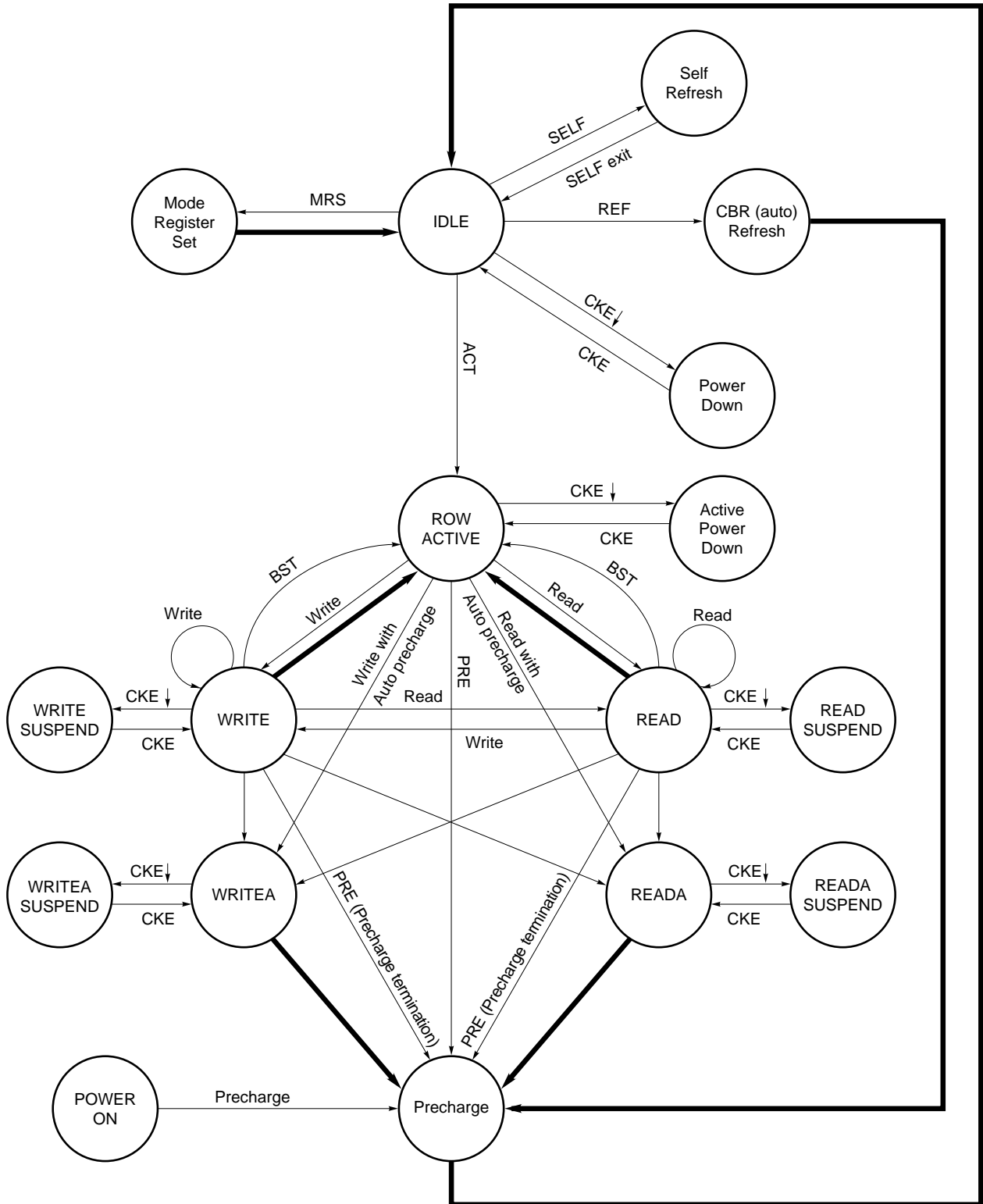

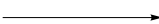
 Automatic sequence
 Manual input

4. Truth Table

4.1 Command Truth Table

Function	Symbol	CKE		/CS	/RAS	/CAS	/WE	A12, A13	A10	A11, A9 - A0
		n - 1	n							
Device deselect	DESL	H	×	H	×	×	×	×	×	×
No operation	NOP	H	×	L	H	H	H	×	×	×
Burst stop	BST	H	×	L	H	H	L	×	×	×
Read	READ	H	×	L	H	L	H	V	L	V
Read with auto precharge	READA	H	×	L	H	L	H	V	H	V
Write	WRIT	H	×	L	H	L	L	V	L	V
Write with auto precharge	WRITA	H	×	L	H	L	L	V	H	V
Bank activate	ACT	H	×	L	L	H	H	V	V	V
Precharge select bank	PRE	H	×	L	L	H	L	V	L	×
Precharge all banks	PALL	H	×	L	L	H	L	×	H	×
Mode register set	MRS	H	×	L	L	L	L	L	L	V

Remark H = High level, L = Low level, × = High or Low level (Don't care), V = Valid data input

4.2 DQM Truth Table

Function	Symbol	CKE		DQM	
		n - 1	n	U	L
Data write / output enable	ENB	H	×	L	
Data mask / output disable	MASK	H	×	H	
Upper byte write enable / output enable	ENBU	H	×	L	×
Lower byte write enable / output enable	ENBL	H	×	×	L
Upper byte write inhibit / output disable	MASKU	H	×	H	×
Lower byte write inhibit / output disable	MASKL	H	×	×	H

Remark H = High level, L = Low level, × = High or Low level (Don't care)

4.3 CKE Truth Table

Current state	Function	Symbol	CKE		/CS	/RAS	/CAS	/WE	Address
			n - 1	n					
Activating	Clock suspend mode entry		H	L	×	×	×	×	×
Any	Clock suspend mode		L	L	×	×	×	×	×
Clock suspend	Clock suspend mode exit		L	H	×	×	×	×	×
Idle	CBR (auto) refresh command	REF	H	H	L	L	L	H	×
Idle	Self refresh entry	SELF	H	L	L	L	L	H	×
Self refresh	Self refresh exit		L	H	L	H	H	H	×
			L	H	H	×	×	×	×
Idle	Power down entry		H	L	×	×	×	×	×
Power down	Power down exit		L	H	H	×	×	×	×
			L	H	L	H	H	H	×

Remark H = High level, L = Low level, × = High or Low level (Don't care)

4.4 Operative Command Table ^{Note1}

(1/3)

Current state	/CS	/RAS	/CAS	/WE	Address	Command	Action	Notes
Idle	H	×	×	×	×	DESL	Nop or power down	2
	L	H	H	×	×	NOP or BST	Nop or power down	2
	L	H	L	H	BA, CA, A10	READ/READA	ILLEGAL	3
	L	H	L	L	BA, CA, A10	WRIT/WRITA	ILLEGAL	3
	L	L	H	H	BA, RA	ACT	Row activating	
	L	L	H	L	BA, A10	PRE/PALL	Nop	
	L	L	L	H	×	REF/SELF	CBR (auto) refresh or self refresh	4
	L	L	L	L	Op-Code	MRS	Mode register accessing	
Row active	H	×	×	×	×	DESL	Nop	
	L	H	H	×	×	NOP or BST	Nop	
	L	H	L	H	BA, CA, A10	READ/READA	Begin read : Determine AP	5
	L	H	L	L	BA, CA, A10	WRIT/WRITA	Begin write : Determine AP	5
	L	L	H	H	BA, RA	ACT	ILLEGAL	3
	L	L	H	L	BA, A10	PRE/PALL	Precharge	6
	L	L	L	H	×	REF/SELF	ILLEGAL	
	L	L	L	L	Op-Code	MRS	ILLEGAL	
Read	H	×	×	×	×	DESL	Continue burst to end → Row active	
	L	H	H	H	×	NOP	Continue burst to end → Row active	
	L	H	H	L	×	BST	Burst stop → Row active	
	L	H	L	H	BA, CA, A10	READ/READA	Terminate burst, new read : Determine AP	7
	L	H	L	L	BA, CA, A10	WRIT/WRITA	Terminate burst, start write : Determine AP	7, 8
	L	L	H	H	BA, RA	ACT	ILLEGAL	3
	L	L	H	L	BA, A10	PRE/PALL	Terminate burst, precharging	
	L	L	L	H	×	REF/SELF	ILLEGAL	
	L	L	L	L	Op-Code	MRS	ILLEGAL	
Write	H	×	×	×	×	DESL	Continue burst to end → Write recovering	
	L	H	H	H	×	NOP	Continue burst to end → Write recovering	
	L	H	H	L	×	BST	Burst stop → Row active	
	L	H	L	H	BA, CA, A10	READ/READA	Terminate burst, start read : Determine AP	7, 8
	L	H	L	L	BA, CA, A10	WRIT/WRITA	Terminate burst, new write : Determine AP	7
	L	L	H	H	BA, RA	ACT	ILLEGAL	3
	L	L	H	L	BA, A10	PRE/PALL	Terminate burst, precharging	9
	L	L	L	H	×	REF/SELF	ILLEGAL	
	L	L	L	L	Op-Code	MRS	ILLEGAL	

Current state	/CS	/RAS	/CAS	/WE	Address	Command	Action	Notes
Read with auto precharge	H	×	×	×	×	DESL	Continue burst to end → Precharging	
	L	H	H	H	×	NOP	Continue burst to end → Precharging	
	L	H	H	L	×	BST	ILLEGAL	
	L	H	L	H	BA, CA, A10	READ/READA	ILLEGAL	3
	L	H	L	L	BA, CA, A10	WRIT/WRITA	ILLEGAL	3
	L	L	H	H	BA, RA	ACT	ILLEGAL	3
	L	L	H	L	BA, A10	PRE/PALL	ILLEGAL	3
	L	L	L	H	×	REF/SELF	ILLEGAL	
	L	L	L	L	Op-Code	MRS	ILLEGAL	
Write with auto precharge	H	×	×	×	×	DESL	Continue burst to end → Write recovering with auto precharge	
	L	H	H	H	×	NOP	Continue burst to end → Write recovering with auto precharge	
	L	H	H	L	×	BST	ILLEGAL	
	L	H	L	H	BA, CA, A10	READ/READA	ILLEGAL	3
	L	H	L	L	BA, CA, A10	WRIT/WRITA	ILLEGAL	3
	L	L	H	H	BA, RA	ACT	ILLEGAL	3
	L	L	H	L	BA, A10	PRE/PALL	ILLEGAL	3
	L	L	L	H	×	REF/SELF	ILLEGAL	
	L	L	L	L	Op-Code	MRS	ILLEGAL	
Precharging	H	×	×	×	×	DESL	Nop → Enter idle after t _{RP}	
	L	H	H	H	×	NOP	Nop → Enter idle after t _{RP}	
	L	H	H	L	×	BST	ILLEGAL	
	L	H	L	H	BA, CA, A10	READ/READA	ILLEGAL	3
	L	H	L	L	BA, CA, A10	WRIT/WRITA	ILLEGAL	3
	L	L	H	H	BA, RA	ACT	ILLEGAL	3
	L	L	H	L	BA, A10	PRE/PALL	Nop → Enter idle after t _{RP}	
	L	L	L	H	×	REF/SELF	ILLEGAL	
	L	L	L	L	Op-Code	MRS	ILLEGAL	
Row activating	H	×	×	×	×	DESL	Nop → Enter bank active after t _{RCD}	
	L	H	H	H	×	NOP	Nop → Enter bank active after t _{RCD}	
	L	H	H	L	×	BST	ILLEGAL	
	L	H	L	H	BA, CA, A10	READ/READA	ILLEGAL	3
	L	H	L	L	BA, CA, A10	WRIT/WRITA	ILLEGAL	3
	L	L	H	H	BA, RA	ACT	ILLEGAL	3, 10
	L	L	H	L	BA, A10	PRE/PALL	ILLEGAL	3
	L	L	L	H	×	REF/SELF	ILLEGAL	
	L	L	L	L	Op-Code	MRS	ILLEGAL	

Current state	/CS	/RAS	/CAS	/WE	Address	Command	Action	Notes
Write recovering	H	×	×	×	×	DESL	Nop → Enter row active after t _{DPL}	
	L	H	H	H	×	NOP	Nop → Enter row active after t _{DPL}	
	L	H	H	L	×	BST	Nop → Enter row active after t _{DPL}	
	L	H	L	H	BA, CA, A10	READ/READA	Start read, Determine AP	8
	L	H	L	L	BA, CA, A10	WRIT/WRITA	New write, Determine AP	
	L	L	H	H	BA, RA	ACT	ILLEGAL	3
	L	L	H	L	BA, A10	PRE/PALL	ILLEGAL	3
	L	L	L	H	×	REF/SELF	ILLEGAL	
	L	L	L	L	Op-Code	MRS	ILLEGAL	
Write recovering with auto precharge	H	×	×	×	×	DESL	Nop → Enter precharge after t _{DPL}	
	L	H	H	H	×	NOP	Nop → Enter precharge after t _{DPL}	
	L	H	H	L	×	BST	Nop → Enter precharge after t _{DPL}	
	L	H	L	H	BA, CA, A10	READ/READA	ILLEGAL	3, 8
	L	H	L	L	BA, CA, A10	WRIT/WRITA	ILLEGAL	3
	L	L	H	H	BA, RA	ACT	ILLEGAL	3
	L	L	H	L	BA, A10	PRE/PALL	ILLEGAL	
	L	L	L	H	×	REF/SELF	ILLEGAL	
	L	L	L	L	Op-Code	MRS	ILLEGAL	
Refreshing	H	×	×	×	×	DESL	Nop → Enter idle after t _{RC}	
	L	H	H	×	×	NOP/BST	Nop → Enter idle after t _{RC}	
	L	H	L	×	×	READ/WRIT	ILLEGAL	
	L	L	H	×	×	ACT/PRE/PALL	ILLEGAL	
	L	L	L	×	×	REF/SELF/MRS	ILLEGAL	
Mode register accessing	H	×	×	×	×	DESL	Nop → Enter idle after t _{RSC}	
	L	H	H	H	×	NOP	Nop → Enter idle after t _{RSC}	
	L	H	H	L	×	BST	ILLEGAL	
	L	H	L	×	×	READ/WRIT	ILLEGAL	
	L	L	×	×	×	ACT/PRE/PALL/REF/SELF/MRS	ILLEGAL	

- Notes**
1. All entries assume that CKE was active (High level) during the preceding clock cycle.
 2. If all banks are idle, and CKE is inactive (Low level), μPD4564xxx will enter Power down mode. All input buffers except CKE will be disabled.
 3. Illegal to bank in specified states; Function may be legal in the bank indicated by Bank Address (BA), depending on the state of that bank.
 4. If all banks are idle, and CKE is inactive (Low level), μPD4564xxx will enter Self refresh mode. All input buffers except CKE will be disabled.
 5. Illegal if t_{RCD} is not satisfied.
 6. Illegal if t_{RAS} is not satisfied.
 7. Must satisfy burst interrupt condition.
 8. Must satisfy bus contention, bus turn around, and/or write recovery requirements.
 9. Must mask preceding data which don't satisfy t_{DPL}.
 10. Illegal if t_{RRD} is not satisfied.

Remark H = High level, L = Low level, × = High or Low level (Don't care), V = Valid data

4.5 Command Truth Table for CKE

Current State	CKE		/CS	/RAS	/CAS	/WE	Address	Action	Notes
	n – 1	n							
Self refresh	H	x	x	x	x	x	x	INVALID, CLK (n-1) would exit self refresh	
	L	H	H	x	x	x	x	Self refresh recovery	
	L	H	L	H	H	x	x	Self refresh recovery	
	L	H	L	H	L	x	x	ILLEGAL	
	L	H	L	L	x	x	x	ILLEGAL	
	L	L	x	x	x	x	x	Maintain self refresh	
Self refresh recovery	H	H	H	x	x	x	x	Idle after t _{RC}	
	H	H	L	H	H	x	x	Idle after t _{RC}	
	H	H	L	H	L	x	x	ILLEGAL	
	H	H	L	L	x	x	x	ILLEGAL	
	H	L	H	x	x	x	x	ILLEGAL	
	H	L	L	H	H	x	x	ILLEGAL	
	H	L	L	H	L	x	x	ILLEGAL	
Power down	H	x	x	x	x	x		INVALID, CLK (n – 1) would exit power down	
	L	H	H	x	x	x	x	EXIT power down → Idle	
	L	H	L	H	H	H	x	EXIT power down → Idle	
	L	L	x	x	x	x	x	Maintain power down mode	
All banks idle	H	H	H	x	x	x		Refer to operations in Operative Command Table	
	H	H	L	H	x	x		Refer to operations in Operative Command Table	
	H	H	L	L	H	x		Refer to operations in Operative Command Table	
	H	H	L	L	L	H	x	CBR (auto) refresh	
	H	H	L	L	L	L	Op-Code	Refer to operations in Operative Command Table	
	H	L	H	x	x	x		Refer to operations in Operative Command Table	
	H	L	L	H	x	x		Refer to operations in Operative Command Table	
	H	L	L	L	H	x		Refer to operations in Operative Command Table	
	H	L	L	L	L	H	x	Self refresh	1
	H	L	L	L	L	L	Op-Code	Refer to operations in Operative Command Table	
	L	x	x	x	x	x	x	Power down	1
Row active	H	x	x	x	x	x	x	Refer to operations in Operative Command Table	
	L	x	x	x	x	x	x	Power down	1
Any state other than listed above	H	H	x	x	x	x		Refer to operations in Operative Command Table	
	H	L	x	x	x	x	x	Begin clock suspend next cycle	2
	L	H	x	x	x	x	x	Exit clock suspend next cycle	
	L	L	x	x	x	x	x	Maintain clock suspend	

Notes 1. Self refresh can be entered only from the all banks idle state. Power down can be entered only from all banks idle or row active state.

2. Must be legal command as defined in Operative Command Table.

Remark H = High level, L = Low level, x = High or Low level (Don't care)

5. Initialization

The synchronous DRAM is initialized in the power-on sequence according to the following.

- (1) To stabilize internal circuits, when power is applied, a 100 μ s or longer pause must precede any signal toggling.
- (2) After the pause, all banks must be precharged using the Precharge command (The Precharge all banks command is convenient).
- (3) Once the precharge is completed and the minimum t_{RP} is satisfied, the mode register can be programmed. After the mode register set cycle, t_{RSC} (2 CLK minimum) pause must be satisfied as well.
- (4) Two or more CBR (auto) refresh must be performed.

- Remarks**
1. The sequence of Mode register programming and Refresh above may be transposed.
 2. CKE and DQM must be held high until the Precharge command is issued to ensure data-bus Hi-Z.

6. Programming the Mode Register

The mode register is programmed by the Mode register set command using address bits A13 through A0 as data inputs. The register retains data until it is reprogrammed or the device loses power.

The mode register has four fields;

Options : A13 through A7
/CAS latency : A6 through A4
Wrap type : A3
Burst length : A2 through A0

Following mode register programming, no command can be issued before at least 2 CLK have elapsed.

/CAS Latency

/CAS latency is the most critical of the parameters being set. It tells the device how many clocks must elapse before the data will be available.

The value is determined by the frequency of the clock and the speed grade of the device. **13.3 Relationship between Frequency and Latency** shows the relationship of /CAS latency to the clock period and the speed grade of the device.

Burst Length

Burst Length is the number of words that will be output or input in a read or write cycle. After a read burst is completed, the output bus will become Hi-Z.

The burst length is programmable as 1, 2, 4, 8 or full page.

Wrap Type (Burst Sequence)

The wrap type specifies the order in which the burst data will be addressed. This order is programmable as either "Sequential" or "Interleave". The method chosen will depend on the type of CPU in the system.

Some microprocessor cache systems are optimized for sequential addressing and others for interleaved addressing. **7.1 Burst Length and Sequence** shows the addressing sequence for each burst length using them. Both sequences support bursts of 1, 2, 4 and 8. Additionally, sequence supports the full page length.

7. Mode Register

13	12	11	10	9	8	7	6	5	4	3	2	1	0
0	0	0	0	0	0	1							

JEDEC Standard Test Set (refresh counter test)

13	12	11	10	9	8	7	6	5	4	3	2	1	0
x	x	x	x	1	0	0	LTMODE	WT			BL		

Burst Read and Single Write (for Write Through Cache)

13	12	11	10	9	8	7	6	5	4	3	2	1	0
					1	0							

Use in future

13	12	11	10	9	8	7	6	5	4	3	2	1	0
x	x	x	x	x	1	1	V	V	V	V	V	V	V

Vender Specific

13	12	11	10	9	8	7	6	5	4	3	2	1	0
0	0	0	0	0	0	0	LTMODE	WT			BL		

Mode Register Set

V = Valid
x = Don't care

Burst length	Bits2-0	WT = 0	WT = 1
	000	1	1
	001	2	2
	010	4	4
	011	8	8
	100	R	R
	101	R	R
	110	R	R
111	Full page	R	

Wrap type	0	Sequential
	1	Interleave

Latency mode	Bits6-4	/CAS latency
	000	R
	001	R
	010	R
	011	3
	100	R
	101	R
	110	R
111	R	

Remark R : Reserved

Mode Register Set Timing

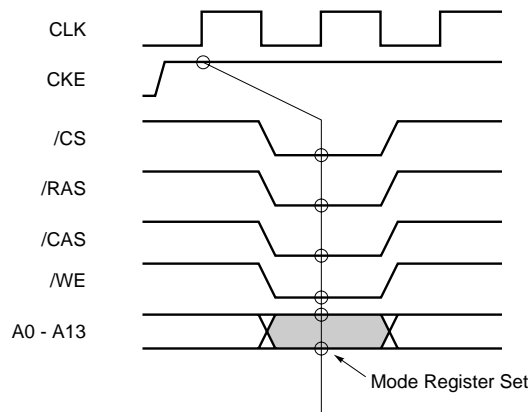

7.1 Burst Length and Sequence

[Burst of Two]

Starting address (column address A0, binary)	Sequential addressing sequence (decimal)	Interleave addressing sequence (decimal)
0	0, 1	0, 1
1	1, 0	1, 0

[Burst of Four]

Starting address (column address A1 - A0, binary)	Sequential addressing sequence (decimal)	Interleave addressing sequence (decimal)
00	0, 1, 2, 3	0, 1, 2, 3
01	1, 2, 3, 0	1, 0, 3, 2
10	2, 3, 0, 1	2, 3, 0, 1
11	3, 0, 1, 2	3, 2, 1, 0

[Burst of Eight]

Starting address (column address A2 - A0, binary)	Sequential addressing sequence (decimal)	Interleave addressing sequence (decimal)
000	0, 1, 2, 3, 4, 5, 6, 7	0, 1, 2, 3, 4, 5, 6, 7
001	1, 2, 3, 4, 5, 6, 7, 0	1, 0, 3, 2, 5, 4, 7, 6
010	2, 3, 4, 5, 6, 7, 0, 1	2, 3, 0, 1, 6, 7, 4, 5
011	3, 4, 5, 6, 7, 0, 1, 2	3, 2, 1, 0, 7, 6, 5, 4
100	4, 5, 6, 7, 0, 1, 2, 3	4, 5, 6, 7, 0, 1, 2, 3
101	5, 6, 7, 0, 1, 2, 3, 4	5, 4, 7, 6, 1, 0, 3, 2
110	6, 7, 0, 1, 2, 3, 4, 5	6, 7, 4, 5, 2, 3, 0, 1
111	7, 0, 1, 2, 3, 4, 5, 6	7, 6, 5, 4, 3, 2, 1, 0

Full page burst is an extension of the above tables of sequential addressing, with the length being 1,024 (for 16M \times 4 device), 512 (for 8M \times 8 device) and 256 (for 4M \times 16 device).

8. Address Bits of Bank-Select and Precharge

Row

A0	A1	A2	A3	A4	A5	A6	A7	A8	A9	A10	A11	A12	A13
----	----	----	----	----	----	----	----	----	----	-----	-----	-----	-----

(Activate command)

A12	A13	Result
0	0	Select Bank A "Activate" command
0	1	Select Bank B "Activate" command
1	0	Select Bank C "Activate" command
1	1	Select Bank D "Activate" command

(Precharge command)

A0	A1	A2	A3	A4	A5	A6	A7	A8	A9	A10	A11	A12	A13
----	----	----	----	----	----	----	----	----	----	-----	-----	-----	-----

A10	A12	A13	Result
0	0	0	Precharge Bank A
0	0	1	Precharge Bank B
0	1	0	Precharge Bank C
0	1	1	Precharge Bank D
1	x	x	Precharge All Banks

x : Don't care

Col.

A0	A1	A2	A3	A4	A5	A6	A7	A8	A9	A10	x	A12	A13
----	----	----	----	----	----	----	----	----	----	-----	---	-----	-----

(/CAS strobes)

0	disables Auto-Precharge (End of Burst)
1	enables Auto-Precharge (End of Burst)

A12	A13	Result
0	0	enables Read/Write commands for Bank A
0	1	enables Read/Write commands for Bank B
1	0	enables Read/Write commands for Bank C
1	1	enables Read/Write commands for Bank D

9. Precharge

The precharge command can be issued anytime after $t_{RAS (MIN.)}$ is satisfied.

Soon after the precharge command is issued, precharge operation performed and the synchronous DRAM enters the idle state after t_{RP} is satisfied. The parameter t_{RP} is the time required to perform the precharge.

The earliest timing in a read cycle that a precharge command can be issued without losing any data in the burst is as follows.

It is depending on the /CAS latency and clock cycle time.

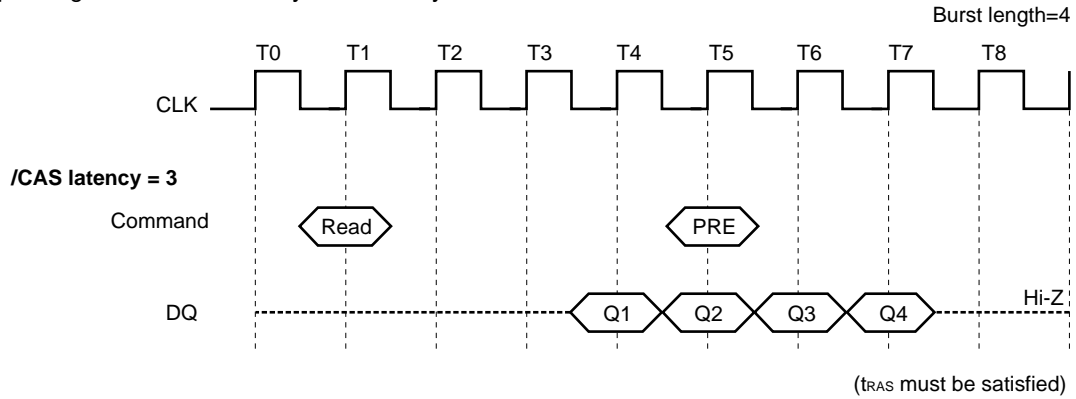

In order to write all data to the memory cell correctly, the asynchronous parameter “ t_{DPL} ” must be satisfied. The $t_{DPL (MIN.)}$ specification defines the earliest time that a precharge command can be issued. Minimum number of clocks is calculated by dividing $t_{DPL (MIN.)}$ with clock cycle time.

In summary, the precharge command can be issued relative to reference clock that indicates the last data word is valid. In the following table, minus means clocks before the reference; plus means time after the reference.

/CAS latency	Read	Write
3	-2	+ $t_{DPL (MIN.)}$

10. Auto Precharge

During a read or write command cycle, A10 controls whether auto precharge is selected. A10 high in the Read or Write command (Read with Auto precharge command or Write with Auto precharge command), auto precharge is selected and begins automatically.

The t_{RAS} must be satisfied with a read with auto precharge or a write with auto precharge operation. In addition, the next activate command to the bank being precharged cannot be executed until the precharge cycle ends.

In read cycle, once auto precharge has started, an activate command to the bank can be issued after t_{RP} has been satisfied.

In write cycle, the t_{DAL} must be satisfied to issue the next activate command to the bank being precharged.

The timing that begins the auto precharge cycle depends on the /CAS latency programmed into the mode register and whether read or write cycle.

10.1 Read with Auto Precharge

During a read cycle, the auto precharge begins two clocks earlier (/CAS latency of 3) the last data word output.

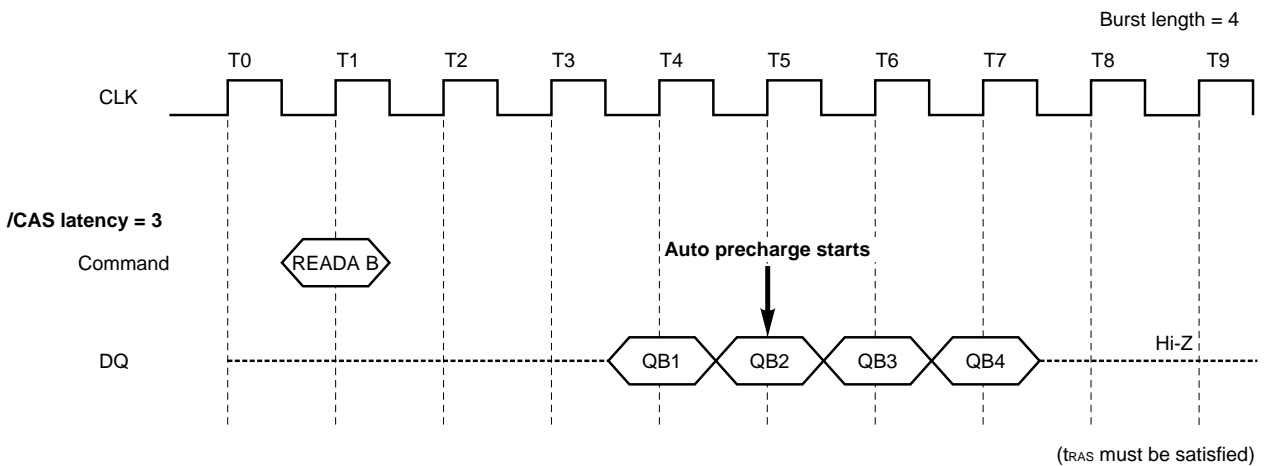

Remark READA means Read with Auto precharge

10.2 Write with Auto Precharge

During a write cycle, the auto precharge starts at the timing that is equal to the value of the $t_{DPL(MIN.)}$ after the last data word input to the device.

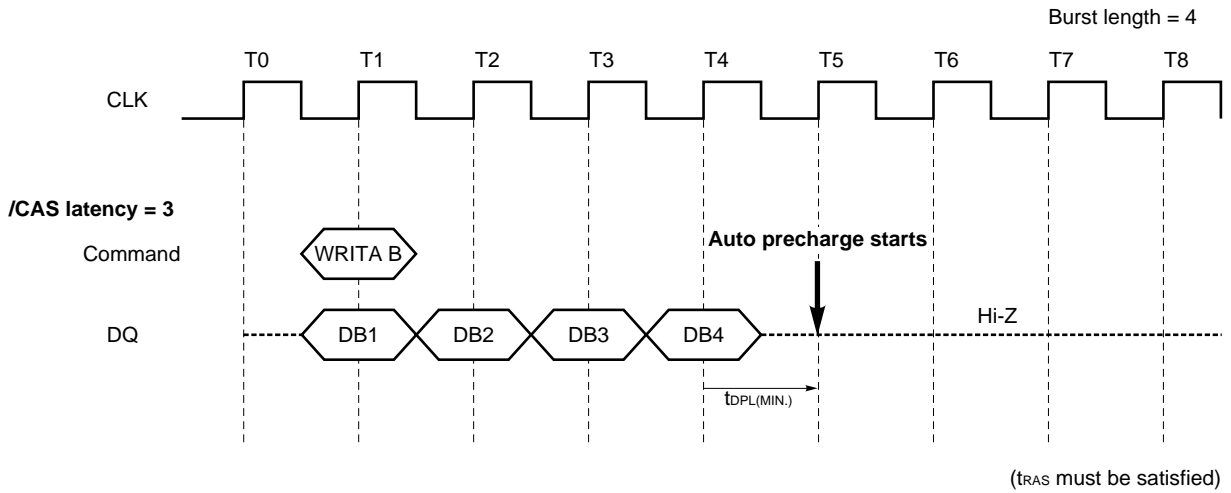

Remark WRITA means Write with Auto Precharge

In summary, the auto precharge begins relative to a reference clock that indicates the last data word is valid. In the table below, minus means clocks before the reference; plus means after the reference.

/CAS latency	Read	Write
3	-2	+ $t_{DPL(MIN.)}$

11. Read / Write Command Interval

11.1 Read to Read Command Interval

During a read cycle, when new Read command is issued, it will be effective after /CAS latency, even if the previous read operation does not completed. READ will be interrupted by another READ.

The interval between the commands is 1 cycle minimum. Each Read command can be issued in every clock without any restriction.

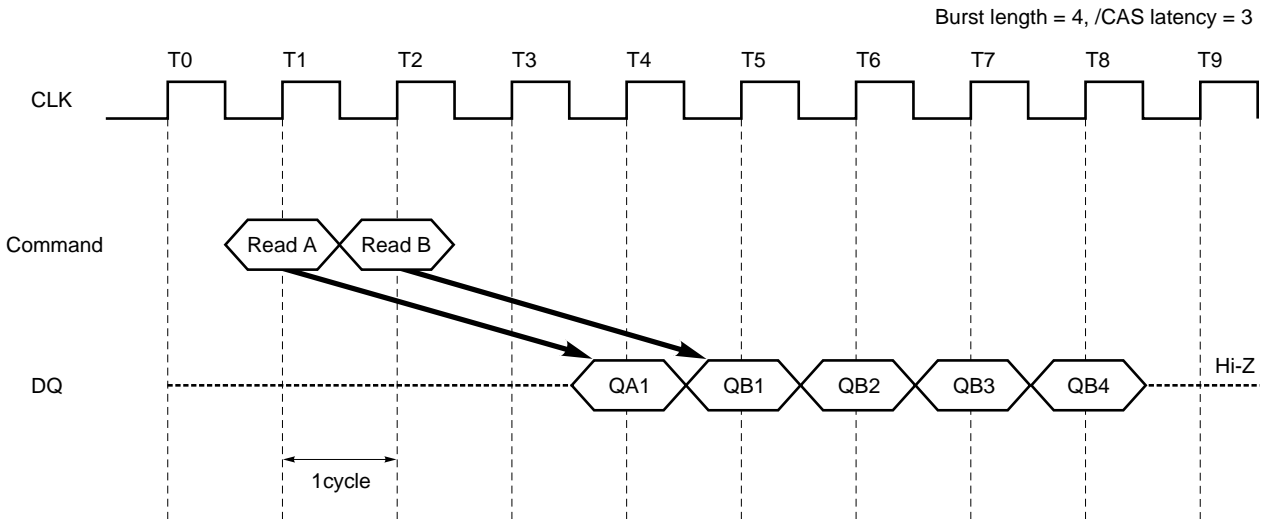

11.2 Write to Write Command Interval

During a write cycle, when a new Write command is issued, the previous burst will terminate and the new burst will begin with a new Write command. WRITE will be interrupted by another WRITE.

The interval between the commands is minimum 1 cycle. Each Write command can be issued in every clock without any restriction.

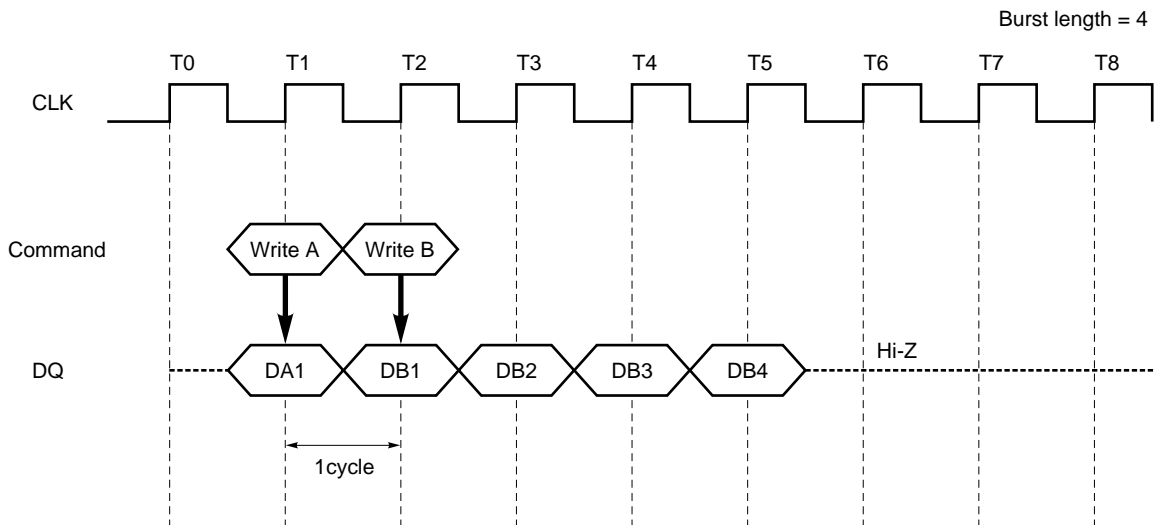

11.3 Write to Read Command Interval

Write command and Read command interval is also 1 cycle.

Only the write data before Read command will be written.

The data bus must be Hi-Z at least one cycle prior to the first DOUT.

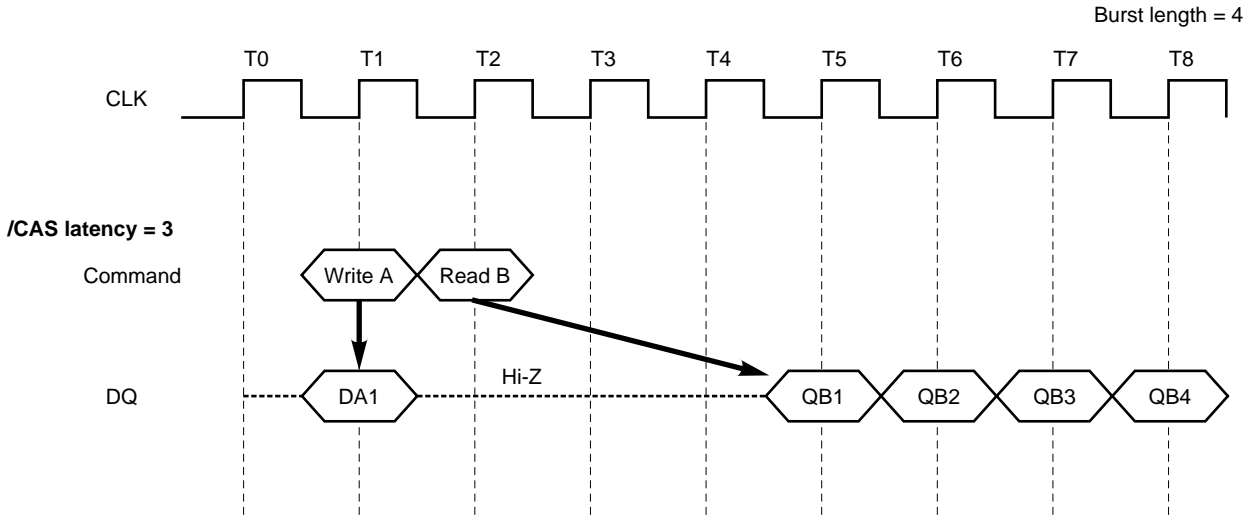

11.4 Read to Write Command Interval

During a read cycle, READ can be interrupted by WRITE.

The Read and Write command interval is 1 cycle minimum. There is a restriction to avoid data conflict. The Data bus must be Hi-Z using DQM before WRITE.

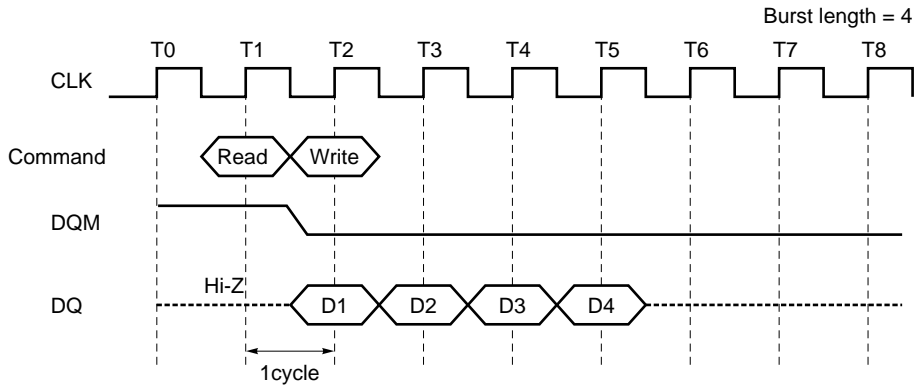

READ can be interrupted by WRITE. DQM must be High at least 3 clocks prior to the Write command.

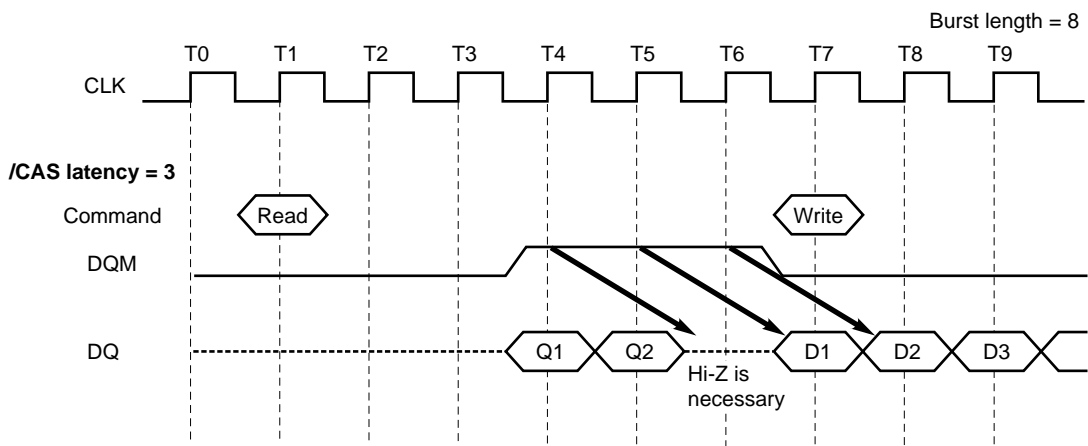

12. Burst Termination

There are two methods to terminate a burst operation other than using a Read or a Write command. One is the burst stop command and the other is the precharge command.

12.1 Burst Stop Command

During a read cycle, when the burst stop command is issued, the burst read data are terminated and the data bus goes to Hi-Z after the /CAS latency from the burst stop command.

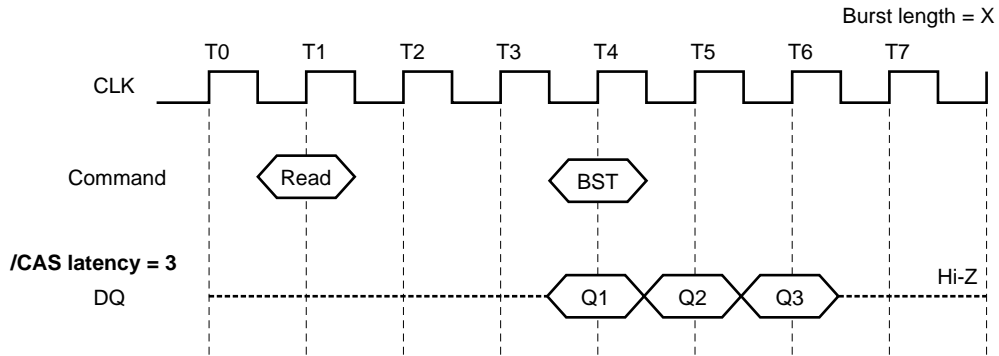

Remark BST: Burst stop command

During a write cycle, when the burst stop command is issued, the burst write data are terminated and data bus goes to Hi-Z at the same clock with the burst stop command.

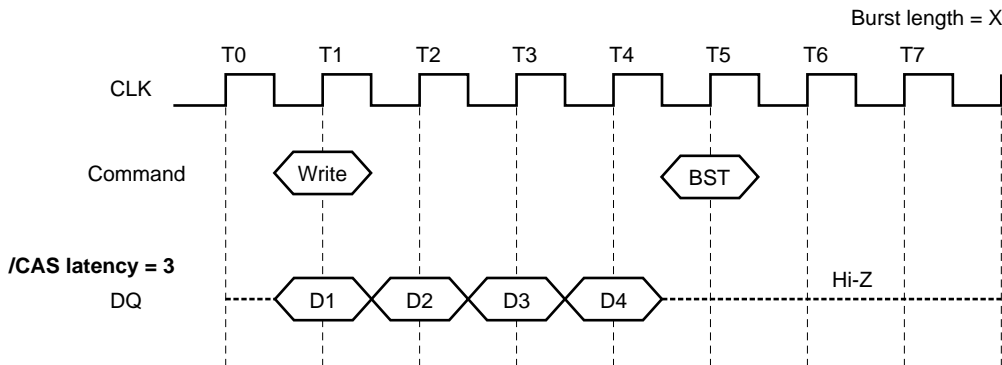

Remark BST: Burst stop command

12.2 Precharge Termination

12.2.1 Precharge Termination in READ Cycle

During a read cycle, the burst read operation is terminated by a precharge command.

When the precharge command is issued, the burst read operation is terminated and precharge starts.

The same bank can be activated again after t_{RP} from the precharge command.

To issue a precharge command, t_{RAS} must be satisfied.

When /CAS latency is 3, the read data will remain valid until two clocks after the precharge command.

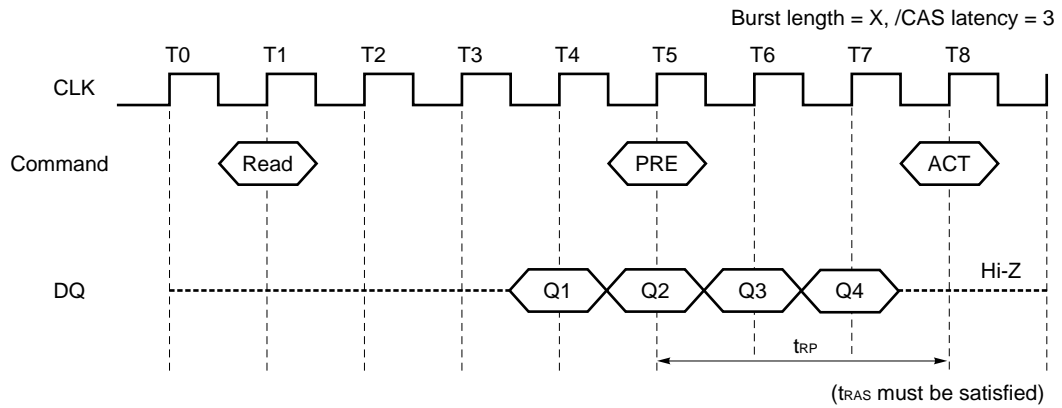

12.2.2 Precharge Termination in WRITE Cycle

During a write cycle, the burst write operation is terminated by a precharge command.

When the precharge command is issued, the burst write operation is terminated and precharge starts.

The same bank can be activated again after t_{RP} from the precharge command.

To issue a precharge command, t_{RAS} must be satisfied.

When /CAS latency is 3, the write data written prior to the precharge command will be correctly stored. However, invalid data may be written at the same clock as the precharge command. To prevent this from happening, DQM must be high at the same clock as the precharge command. This will mask the invalid data.

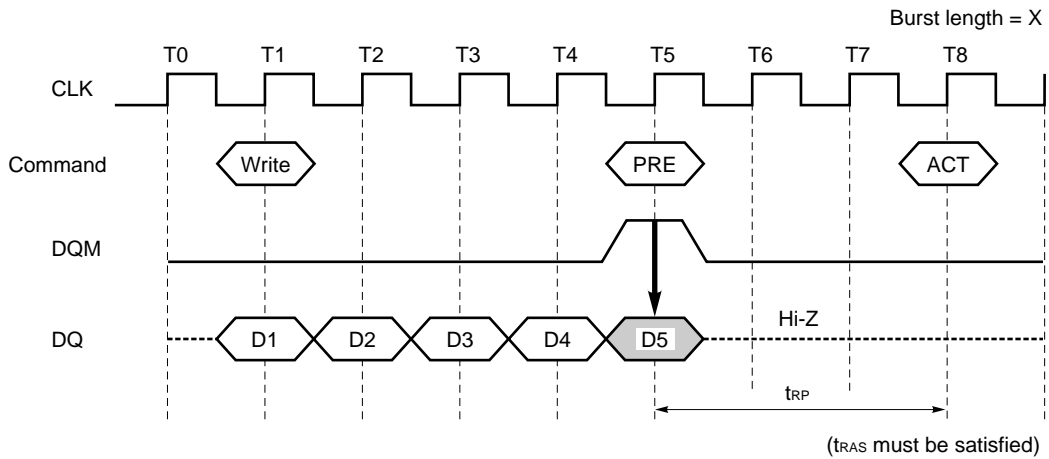

13. Electrical Specifications

- All voltages are referenced to V_{SS} (GND).
- After power up, wait more than 100 μ s and then, execute **Power on sequence and CBR (auto) Refresh** before proper device operation is achieved.

Absolute Maximum Ratings

Parameter	Symbol	Condition	Rating	Unit
Voltage on power supply pin relative to GND	V_{CC}, V_{CCQ}		-0.5 to +4.6	V
Voltage on any pin relative to GND	V_T		-0.5 to +4.6	V
Short circuit output current	I_o		50	mA
Power dissipation	P_D		1	W
Operating ambient temperature	T_A		0 to 70	$^{\circ}$ C
Storage temperature	T_{stg}		-55 to + 125	$^{\circ}$ C

Caution Exposing the device to stress above those listed in Absolute Maximum Ratings could cause permanent damage. The device is not meant to be operated under conditions outside the limits described in the operational section of this specification. Exposure to Absolute Maximum Rating conditions for extended periods may affect device reliability.

Recommended Operating Conditions

Parameter	Symbol	Condition	MIN.	TYP.	MAX.	Unit
Supply voltage	V_{CC}, V_{CCQ}		3.0	3.3	3.6	V
High level input voltage	V_{IH}		2.0		$V_{CC}+0.3$ ^{Note1}	V
Low level input voltage	V_{IL}		-0.3 ^{Note2}		+0.8	V
Operating ambient temperature	T_A		0		70	$^{\circ}$ C

Notes 1. $V_{IH(MAX.)} = V_{CC} + 1.5$ V (Pulse width ≤ 5 ns)

2. $V_{IL(MIN.)} = -1.5$ V (Pulse width ≤ 5 ns)

Pin Capacitance ($T_A = 25$ $^{\circ}$ C, $f = 1$ MHz)

Parameter	Symbol	Condition	MIN.	TYP.	MAX.	Unit
Input capacitance	C_{I1}	CLK	2.5		3.5	pF
	C_{I2}	A0 - A13, CKE, /CS, /RAS, /CAS, /WE, DQM, UDQM, LDQM	2.5		3.8	
Data input / output capacitance	$C_{I/O}$	DQ0 – DQ15	4		6.5	pF

DC Characteristics 1 (Recommended Operating Conditions unless otherwise noted)

Parameter	Symbol	Test condition	/CAS latency	Grade	Maximum			Unit	Notes
					×4	×8	×16		
Operating current	I _{CC1}	Burst length = 1, t _{RC} ≥ t _{RC (MIN.)} , I _O = 0 mA, One bank active	CL = 3	-A75	85	90	120	mA	1
Precharge standby current in power down mode	I _{CC2P}	CKE ≤ V _{IL (MAX.)} , t _{CK} = 15 ns			1	1	1	mA	
	I _{CC2PS}	CKE ≤ V _{IL (MAX.)} , t _{CK} = ∞			1	1	1		
Precharge standby current in non power down mode	I _{CC2N}	CKE ≥ V _{IH (MIN.)} , t _{CK} = 15 ns, /CS ≥ V _{IH (MIN.)} , Input signals are changed one time during 30 ns.			20	20	20	mA	
	I _{CC2NS}	CKE ≥ V _{IH (MIN.)} , t _{CK} = ∞, Input signals are stable.			6	6	6		
Active standby current in power down mode	I _{CC3P}	CKE ≤ V _{IL (MAX.)} , t _{CK} = 15 ns			5	5	5	mA	
	I _{CC3PS}	CKE ≤ V _{IL (MAX.)} , t _{CK} = ∞			4	4	4		
Active standby current in non power down mode	I _{CC3N}	CKE ≥ V _{IH (MIN.)} , t _{CK} = 15 ns, /CS ≥ V _{IH (MIN.)} , Input signals are changed one time during 30 ns.			25	25	25	mA	
	I _{CC3NS}	CKE ≥ V _{IH (MIN.)} , t _{CK} = ∞, Input signals are stable.			15	15	15		
Operating current (Burst mode)	I _{CC4}	t _{CK} ≥ t _{CK (MIN.)} , I _O = 0 mA, All banks active	CL = 3	-A75	115	135	205	mA	2
CBR (auto) refresh current	I _{CC5}	t _{RC} ≥ t _{RC (MIN.)}	CL = 3	-A75	140	140	140	mA	3
Self refresh current	I _{CC6}	CKE ≤ 0.2 V			1	1	1	mA	

- Notes**
1. I_{CC1} depends on output loading and cycle rates. Specified values are obtained with the output open. In addition to this, I_{CC1} is measured condition that addresses are changed only one time during t_{CK (MIN.)}.
 2. I_{CC4} depends on output loading and cycle rates. Specified values are obtained with the output open. In addition to this, I_{CC4} is measured condition that addresses are changed only one time during t_{CK (MIN.)}.
 3. I_{CC5} is measured on condition that addresses are changed only one time during t_{CK (MIN.)}.

DC Characteristics 2 (Recommended Operating Conditions unless otherwise noted)

Parameter	Symbol	Test condition	MIN.	TYP.	MAX.	Unit	Note
Input leakage current	I _{I (L)}	0 ≤ V _I ≤ V _{CCQ} , V _{CCQ} = V _{CC} All other pins not under test = 0 V	-1.0		+1.0	μA	
Output leakage current	I _{O (L)}	0 ≤ V _O ≤ V _{CCQ} , D _{OUT} is disabled	-1.5		+1.5	μA	
High level output voltage	V _{OH}	I _O = -4 mA	2.4			V	
Low level output voltage	V _{OL}	I _O = +4 mA			0.4	V	

AC Characteristics (Recommended Operating Conditions unless otherwise noted)

Test Conditions

Parameter	Value	Unit
AC high level input voltage / low level input voltage	2.4 / 0.4	V
Input timing measurement reference level	1.4	V
Transition time (Input rise and fall time)	1	ns
Output timing measurement reference level	1.4	V

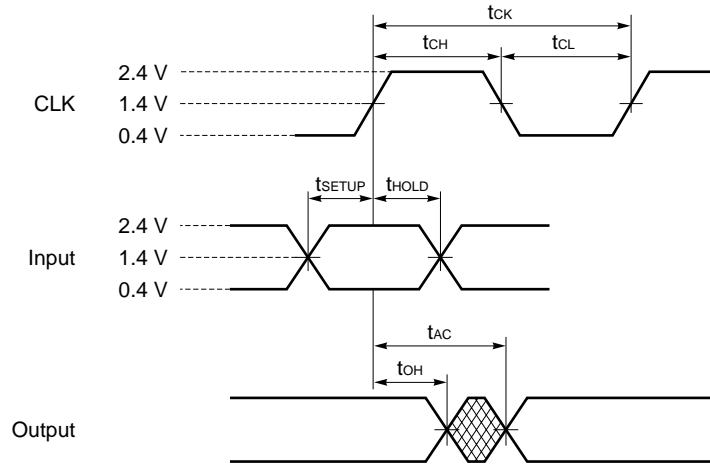

Synchronous Characteristics

Parameter		Symbol	-A75		Unit	Note
			MIN.	MAX.		
Clock cycle time	/CAS latency = 3	t _{CK3}	7.5	(133 MHz)	ns	
Access time from CLK	/CAS latency = 3	t _{AC3}		5.4	ns	1
CLK high level width		t _{CH}	2.5		ns	
CLK low level width		t _{CL}	2.5		ns	
Data-out hold time	/CAS latency = 3	t _{OH3}	2.7		ns	1
Data-out low-impedance time		t _{LZ}	0		ns	
Data-out high-impedance time	/CAS latency = 3	t _{HZ3}	3	6	ns	
Data-in setup time		t _{DS}	1.5		ns	
Data-in hold time		t _{DH}	0.8		ns	
Address setup time		t _{AS}	1.5		ns	
Address hold time		t _{AH}	0.8		ns	
CKE setup time		t _{CKS}	1.5		ns	
CKE hold time		t _{CKH}	0.8		ns	
CKE setup time (Power down exit)		t _{CKSP}	1.5		ns	
Command (/CS, /RAS, /CAS, /WE, DQM) setup time		t _{CMS}	1.5		ns	
Command (/CS, /RAS, /CAS, /WE, DQM) hold time		t _{CMH}	0.8		ns	

Note 1. Output load

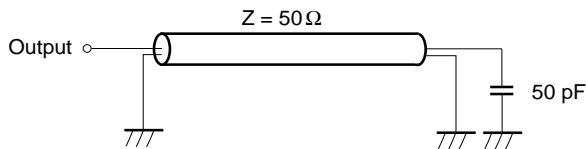

Asynchronous Characteristics

Parameter		Symbol	-A75		Unit	Note
			MIN.	MAX.		
ACT to REF/ACT command period (operation)		t _{RC}	67.5		ns	
REF to REF/ACT command period (refresh)		t _{RC1}	67.5		ns	
ACT to PRE command period		t _{RAS}	45	120,000	ns	
PRE to ACT command period		t _{RP}	20		ns	
Delay time ACT to READ/WRITE command		t _{RCD}	20		ns	
ACT (one) to ACT (another) command period		t _{RRD}	15		ns	
Data-in to PRE command period	/CAS latency = 3	t _{DPL3}	8		ns	
Data-in to ACT (REF) command period (Auto precharge)	/CAS latency = 3	t _{DAL3}	1 CLK + 20		ns	
Mode register set cycle time		t _{RSC}	2		CLK	
Transition time		t _r	0.5	30	ns	
Refresh time (4,096 refresh cycles)		t _{REF}		64	ms	

13.1 AC Parameters for Read Timing (Manual Precharge, Burst Length = 4, /CAS Latency = 3)

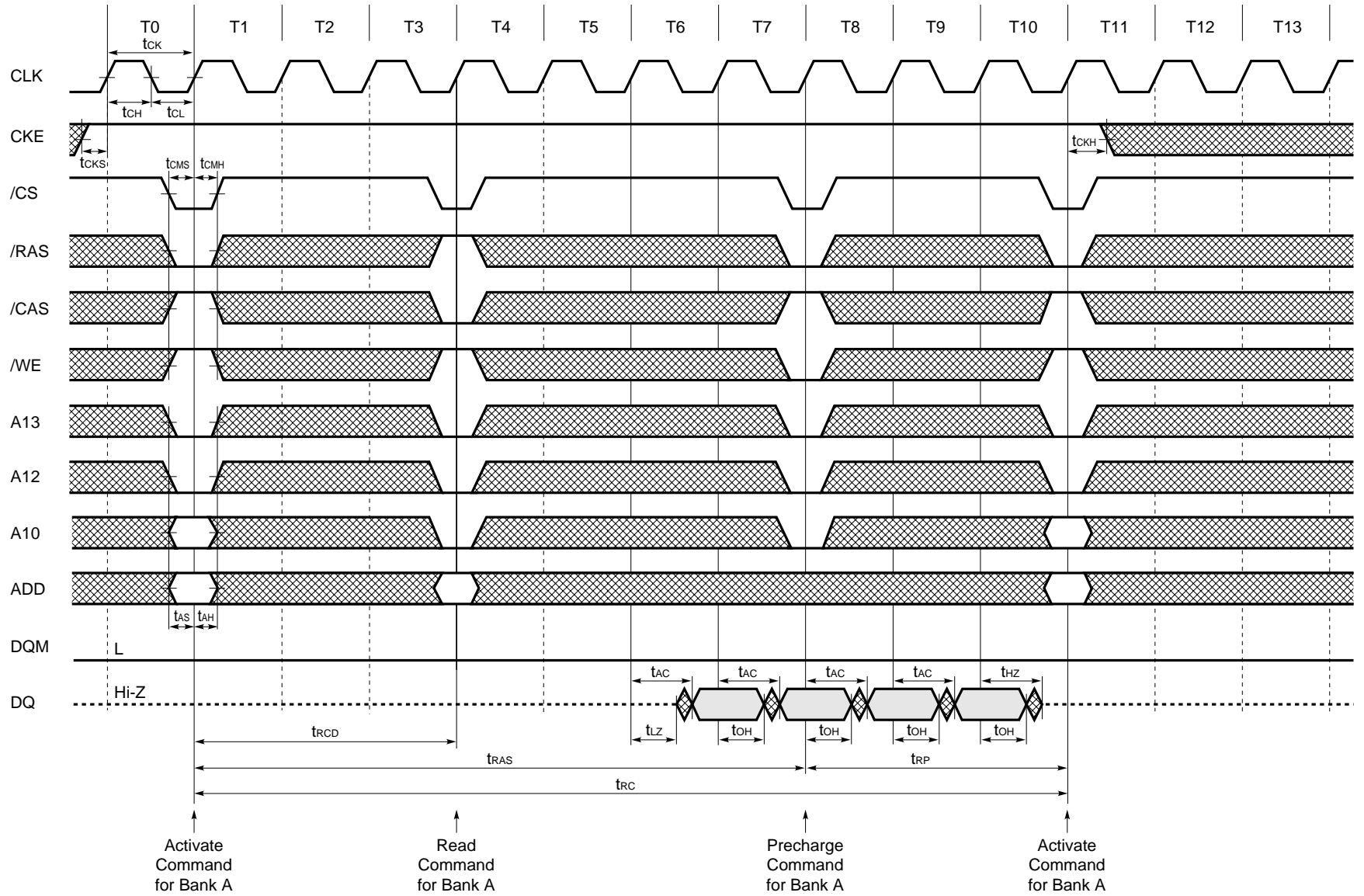

AC Parameters for Read Timing (Auto Precharge, Burst Length = 4, /CAS Latency = 3)

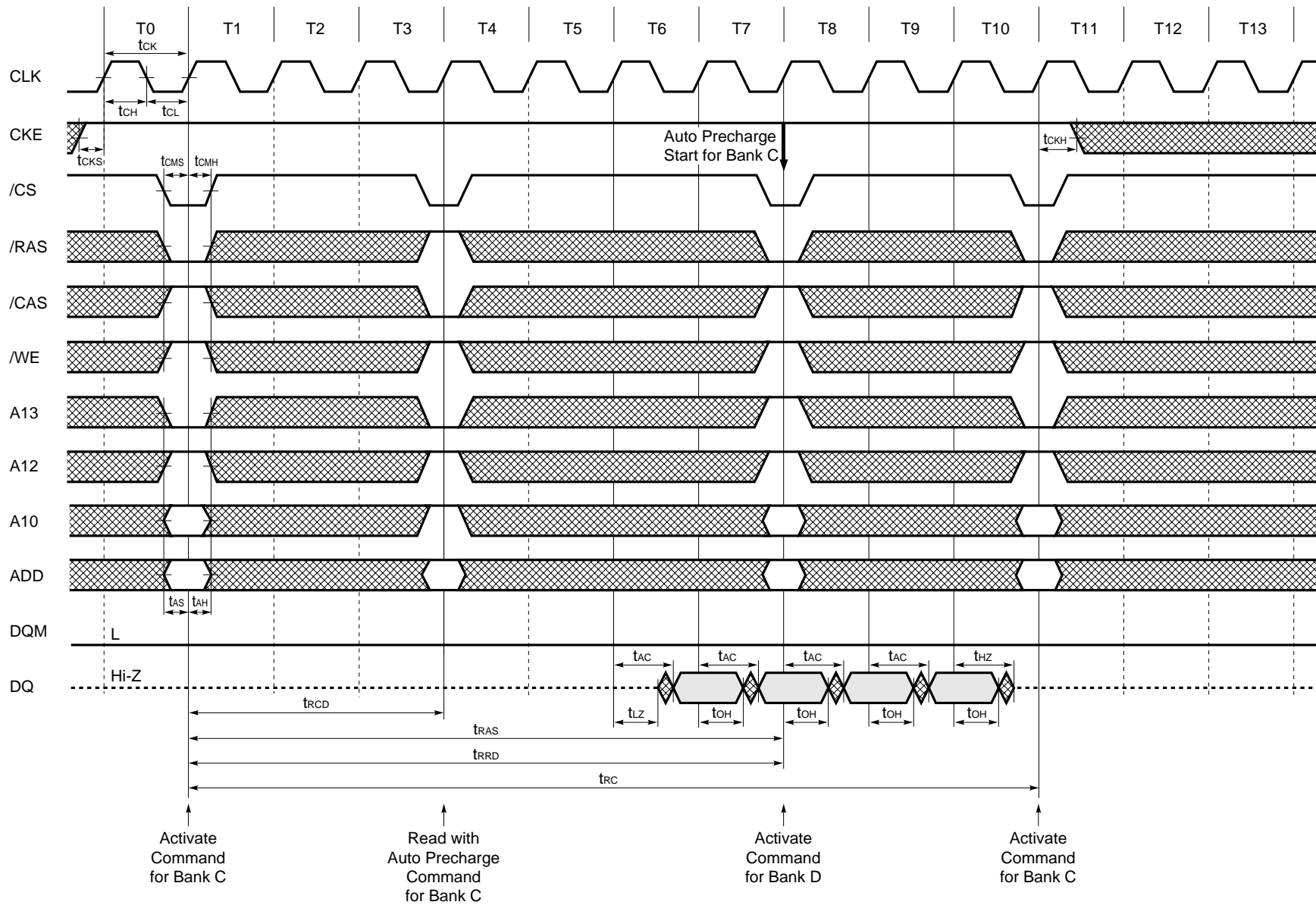

13.2 AC Parameters for Write Timing (Burst Length = 4, /CAS Latency = 3)

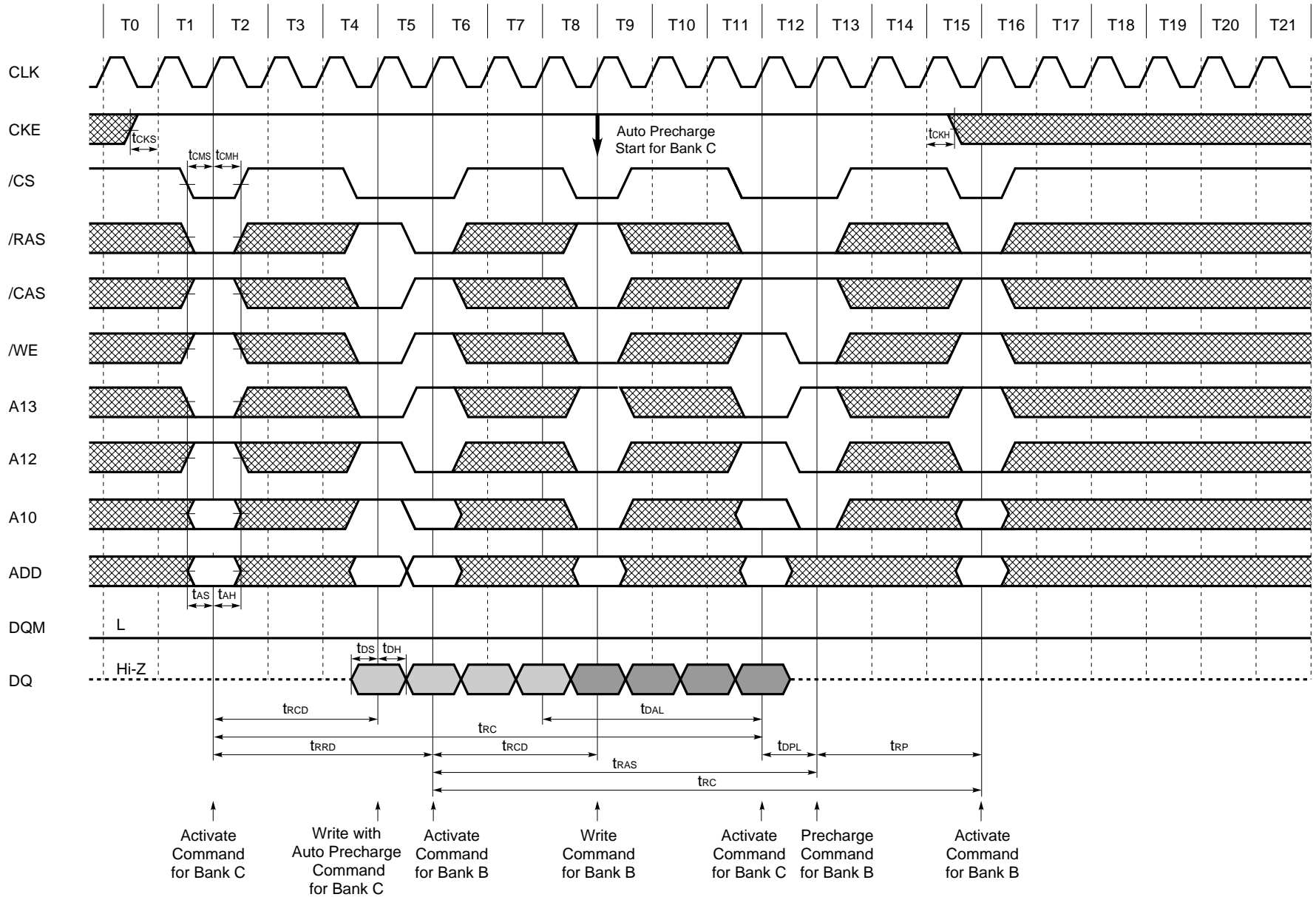

13.3 Relationship between Frequency and Latency

Speed version	-A75
Clock cycle time [ns]	7.5
Frequency [MHz]	133
/CAS latency	3
[t _{RCD}]	3
/RAS latency (/CAS latency + [t _{RCD}])	6
[t _{RC}]	9
[t _{RC1}]	9
[t _{RAS}]	6
[t _{RRD}]	2
[t _{RP}]	3
[t _{DPL}]	2
[t _{DAL}]	4
[t _{RSC}]	2

13.4 Mode Register Set (Burst Length = 4, /CAS Latency = 3)

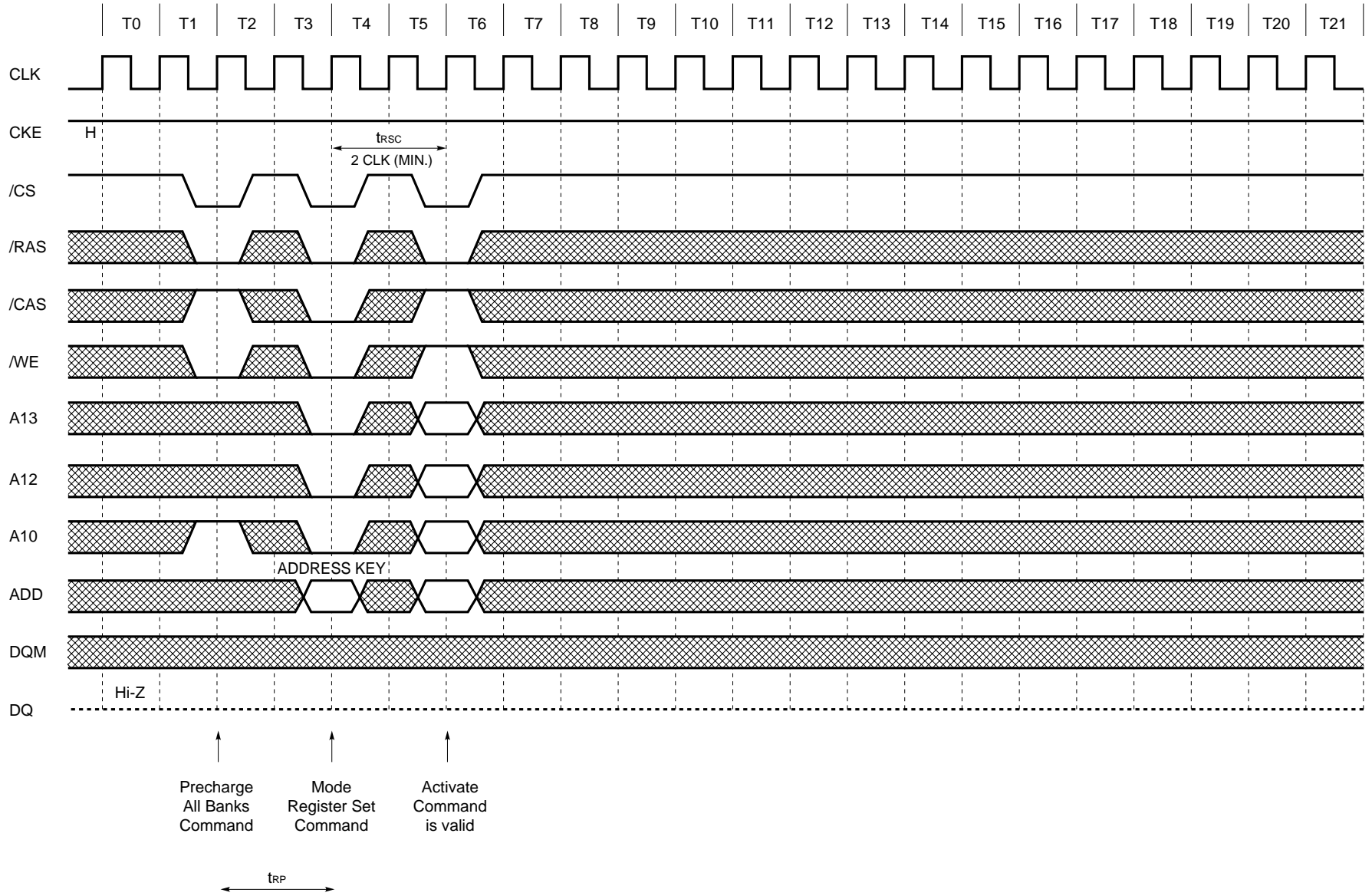

13.5 Power On Sequence and CBR (Auto) Refresh

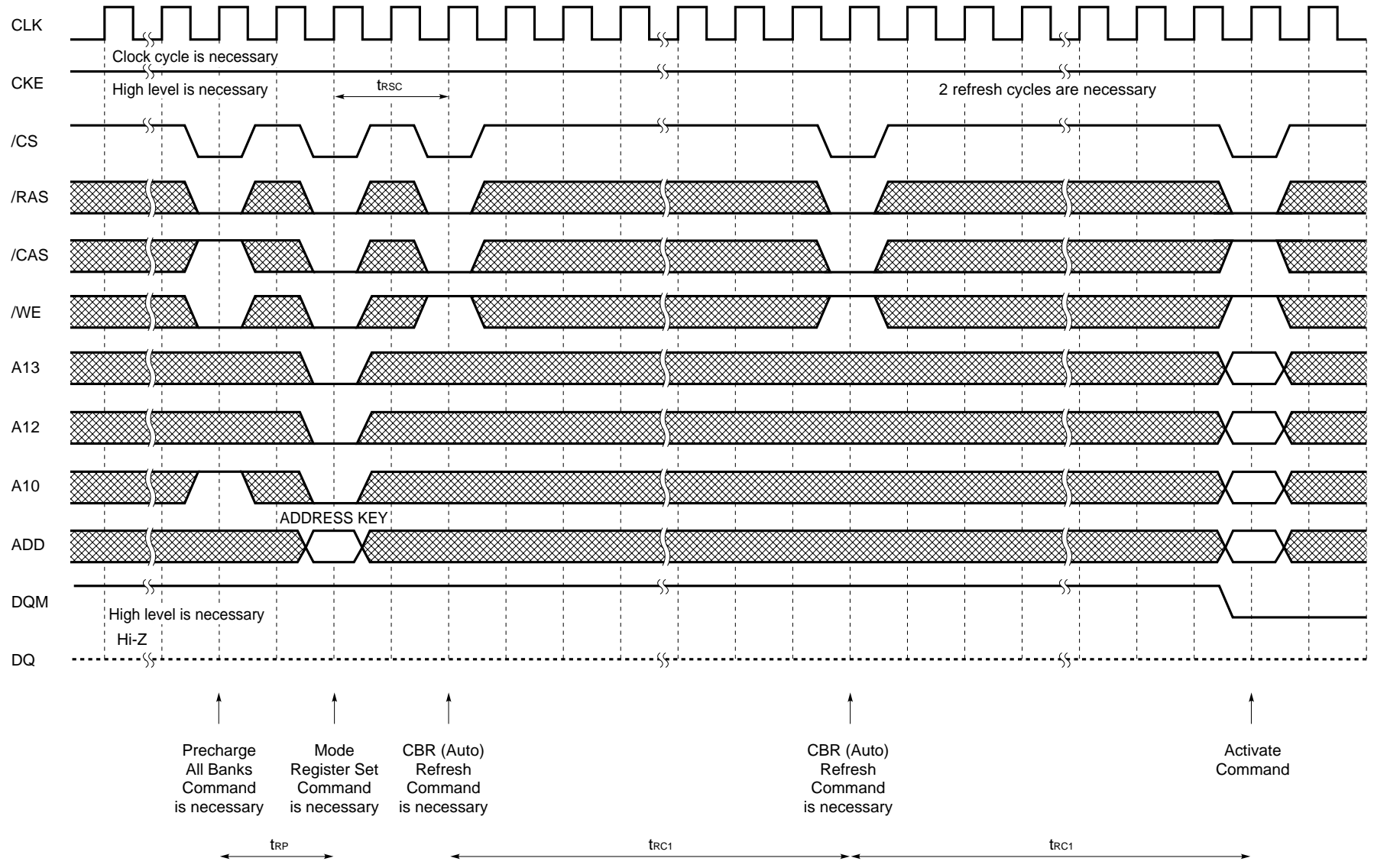

44

13.6 /CS Function (Burst Length = 4, /CAS Latency = 3)
 Only /CS signal needs to be issued at minimum rate

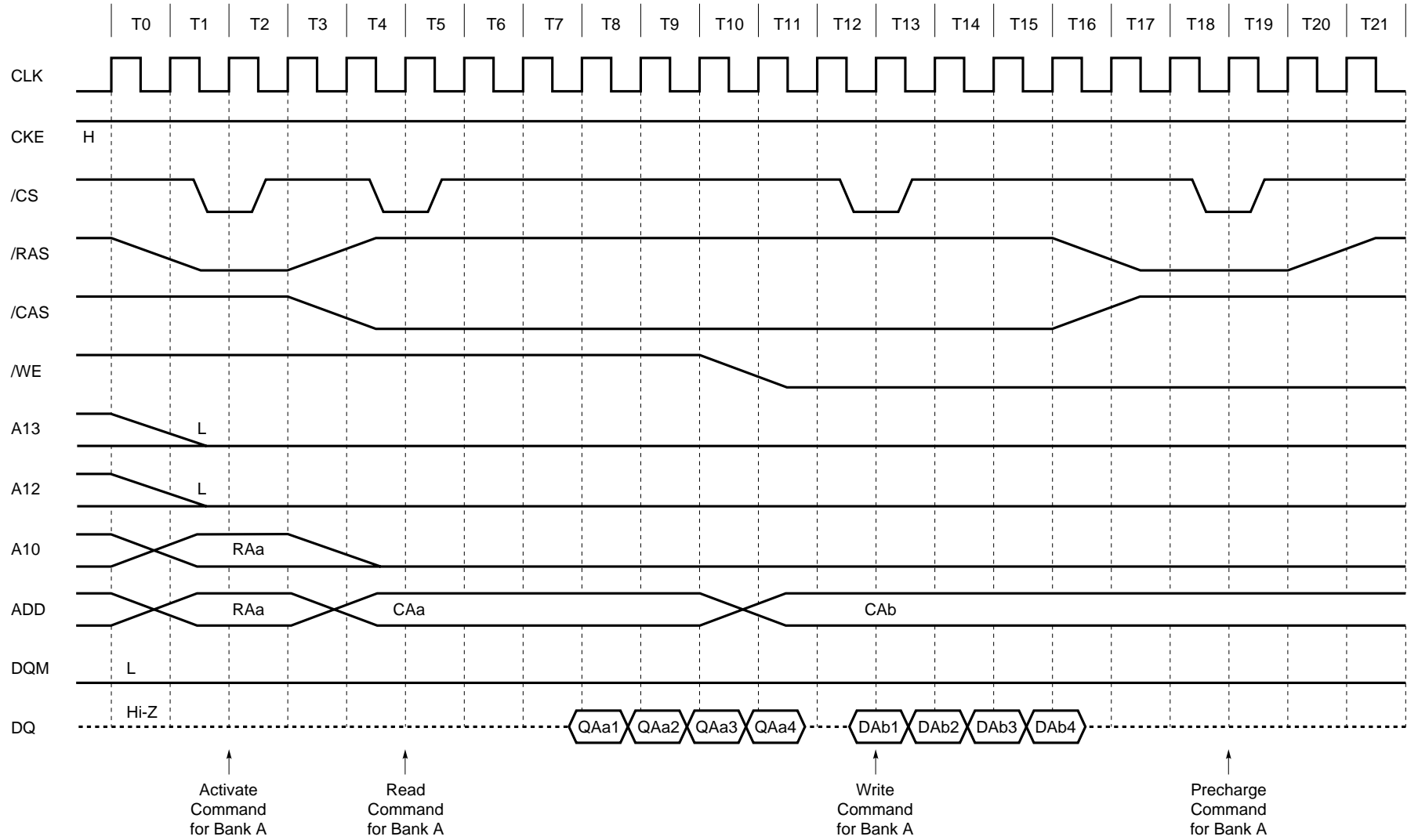

13.7 Clock Suspension during Burst Read (using CKE Function) (Burst Length = 4, /CAS Latency = 3)

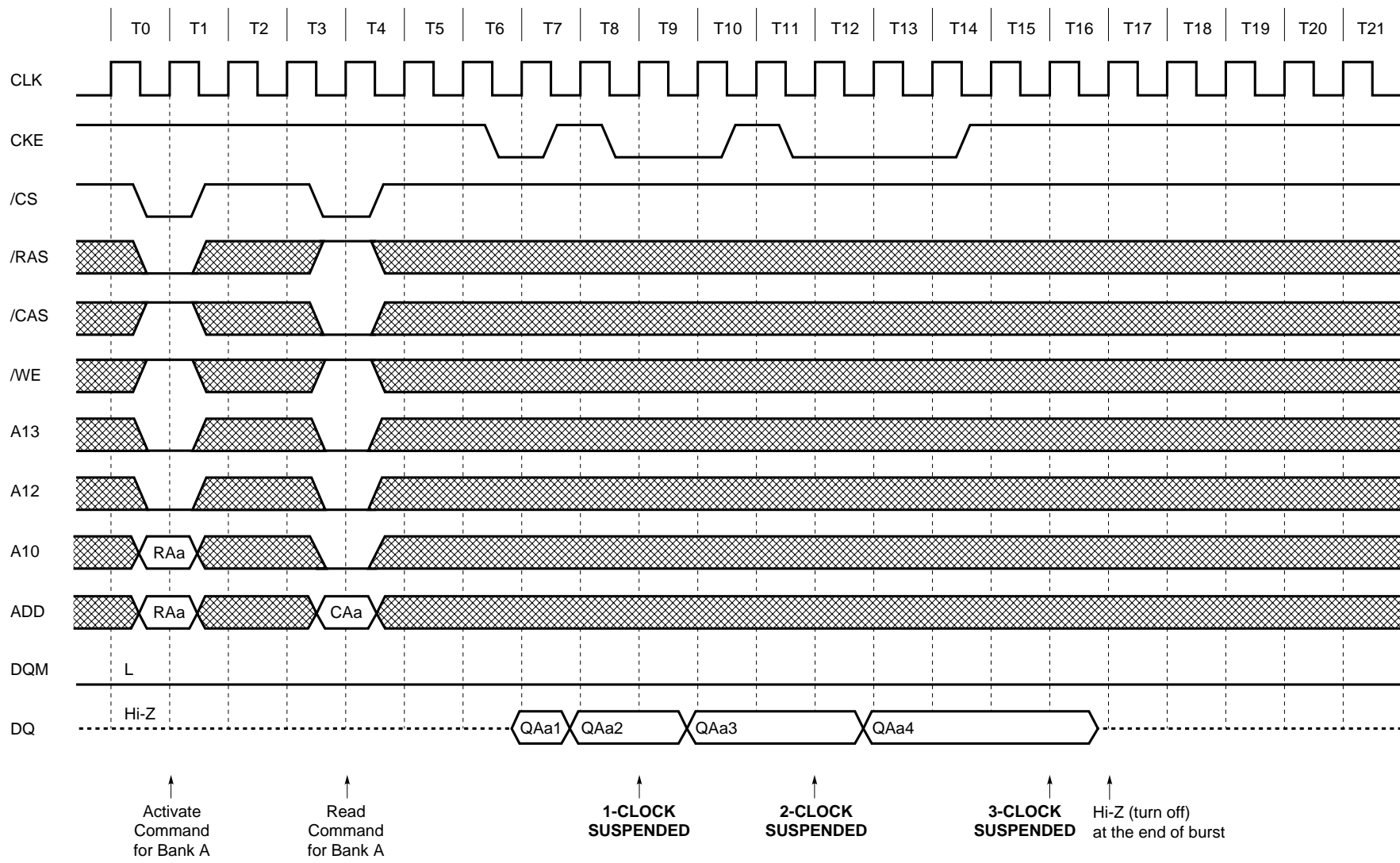

13.8 Clock Suspension during Burst Write (using CKE Function) (Burst Length = 4, /CAS Latency = 3)

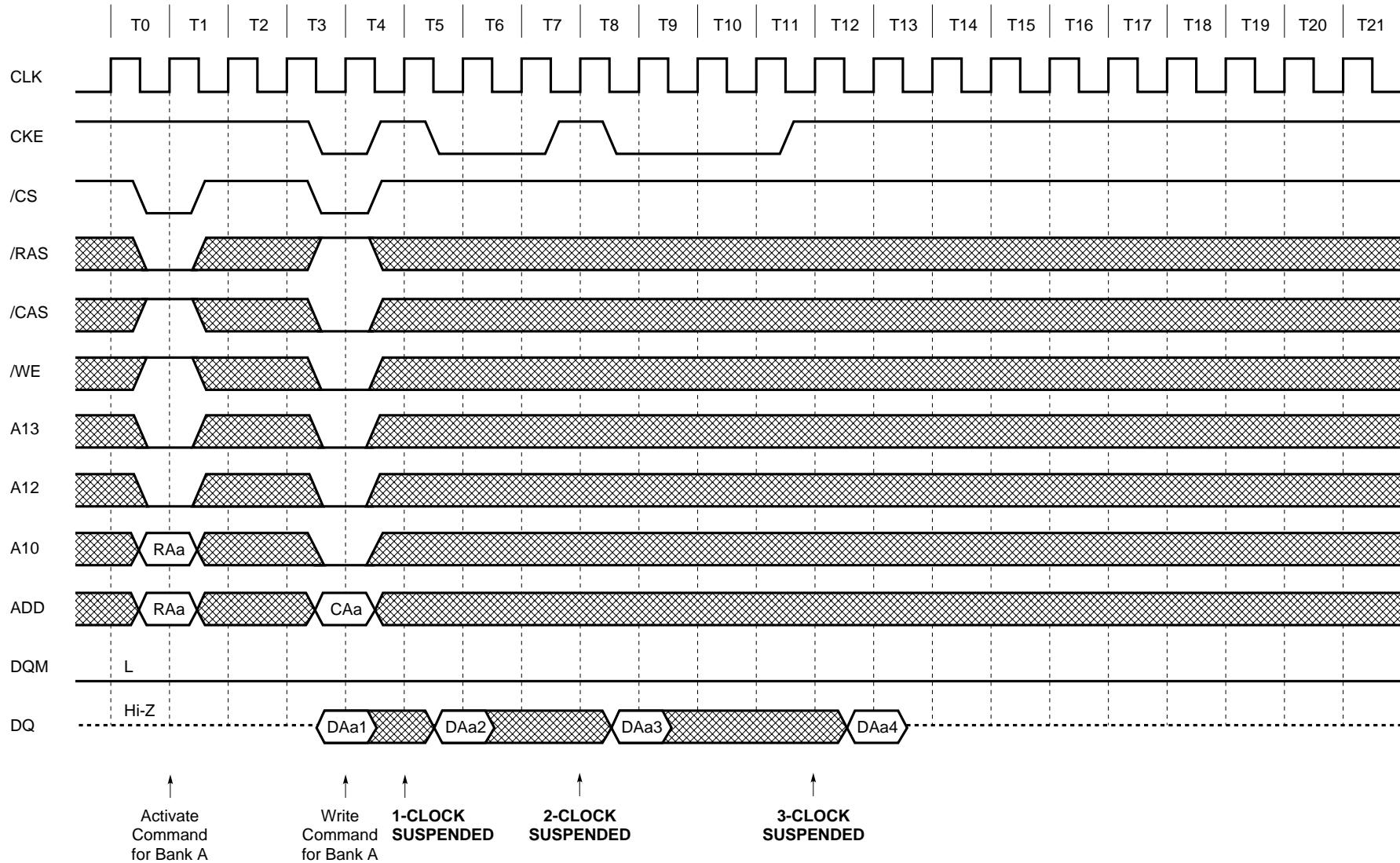

13.9 Power Down Mode and Clock Mask (Burst Length = 4, /CAS Latency = 3)

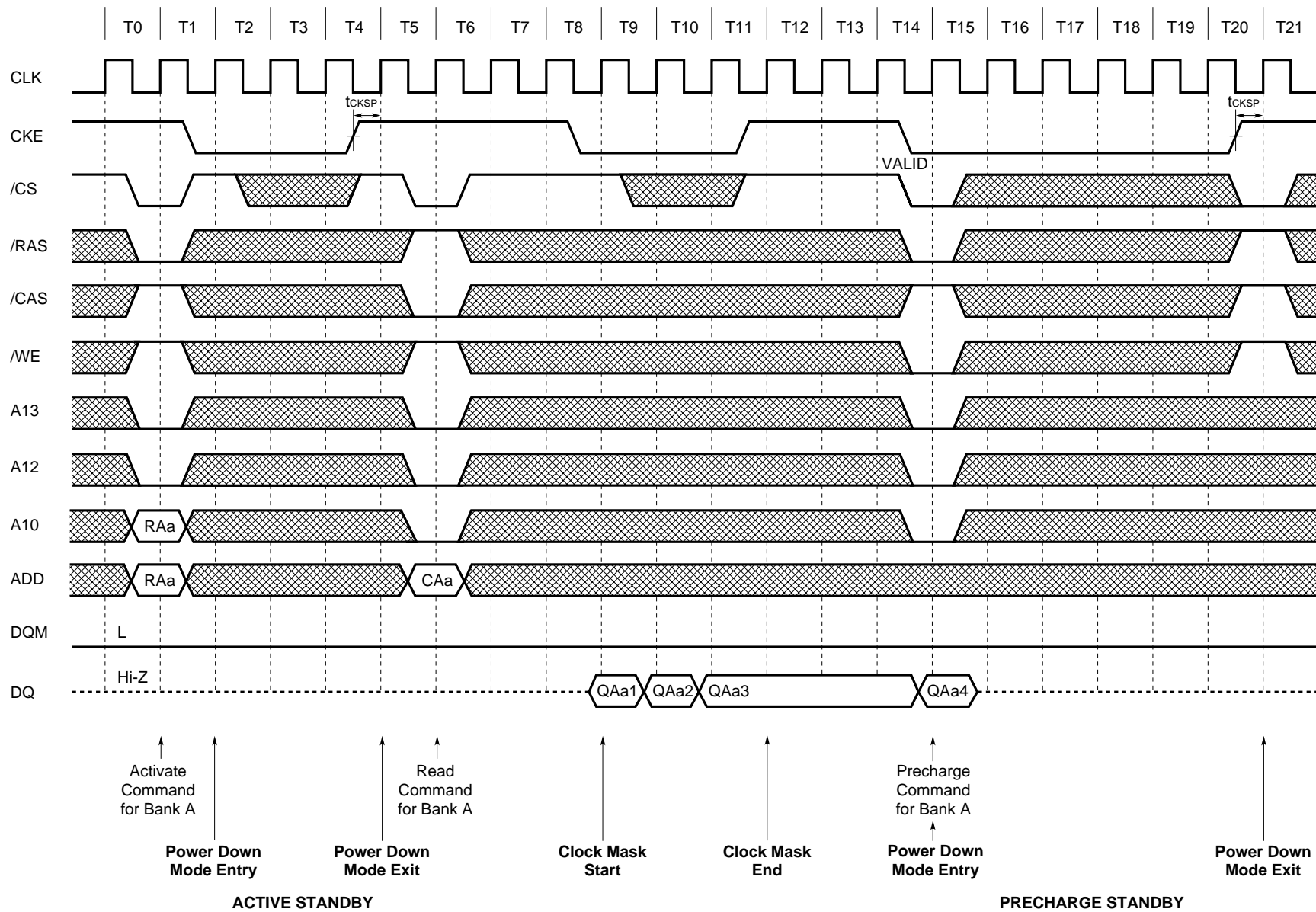

13.10 CBR (Auto) Refresh

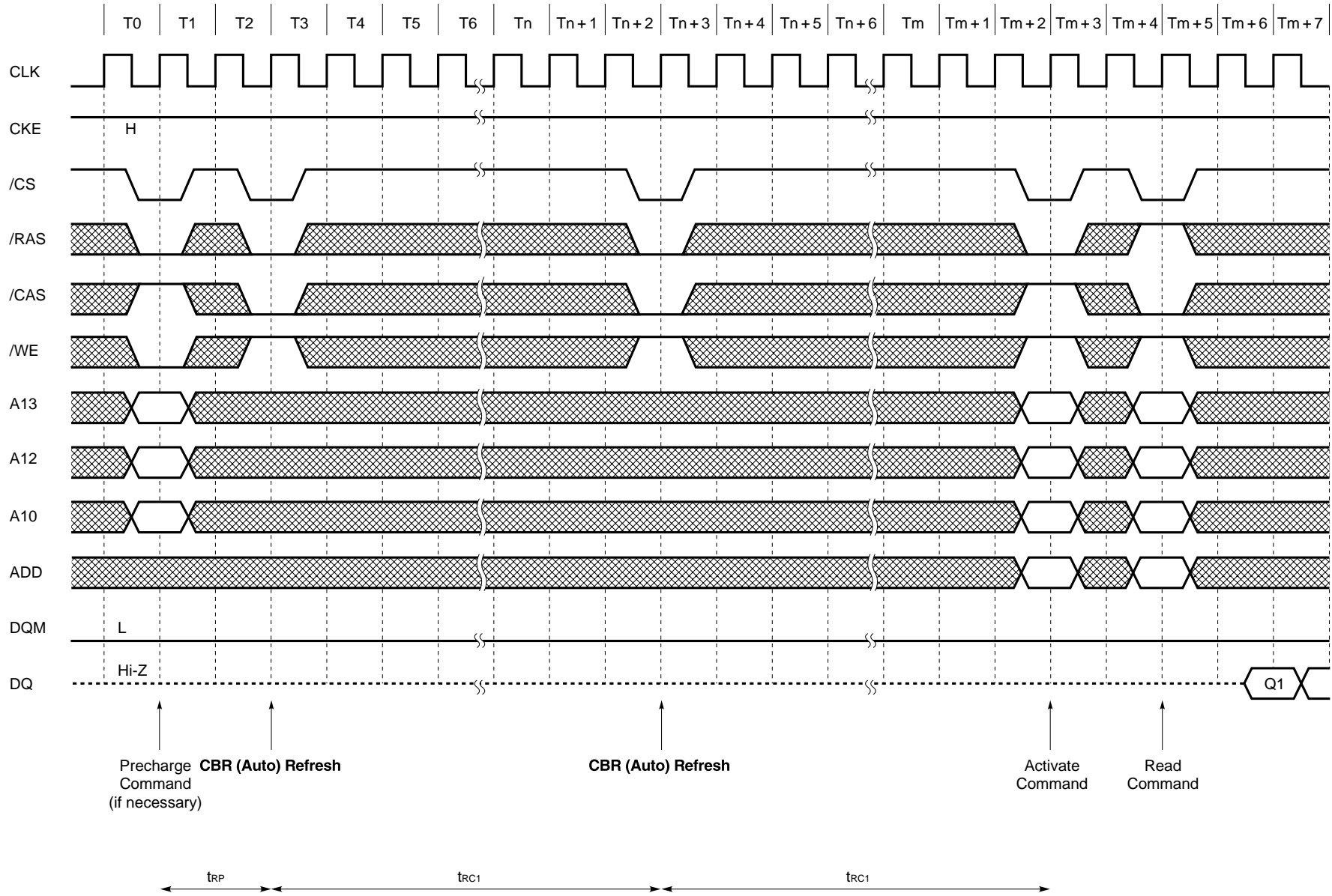

Data Sheet E0150N10

13.11 Self Refresh (Entry and Exit)

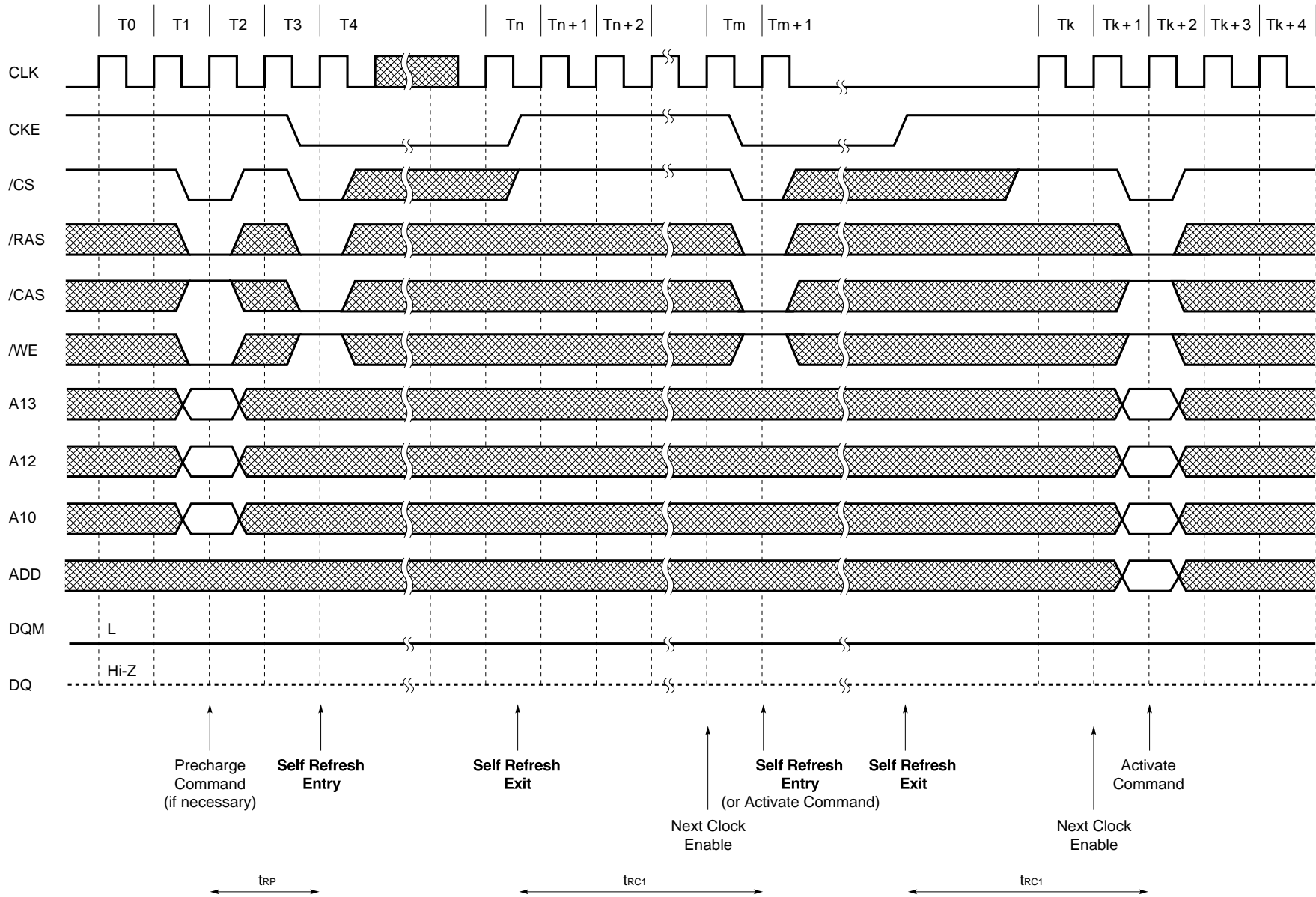

13.12 Random Column Read (Page with Same Bank) (Burst Length = 4, /CAS Latency = 3)

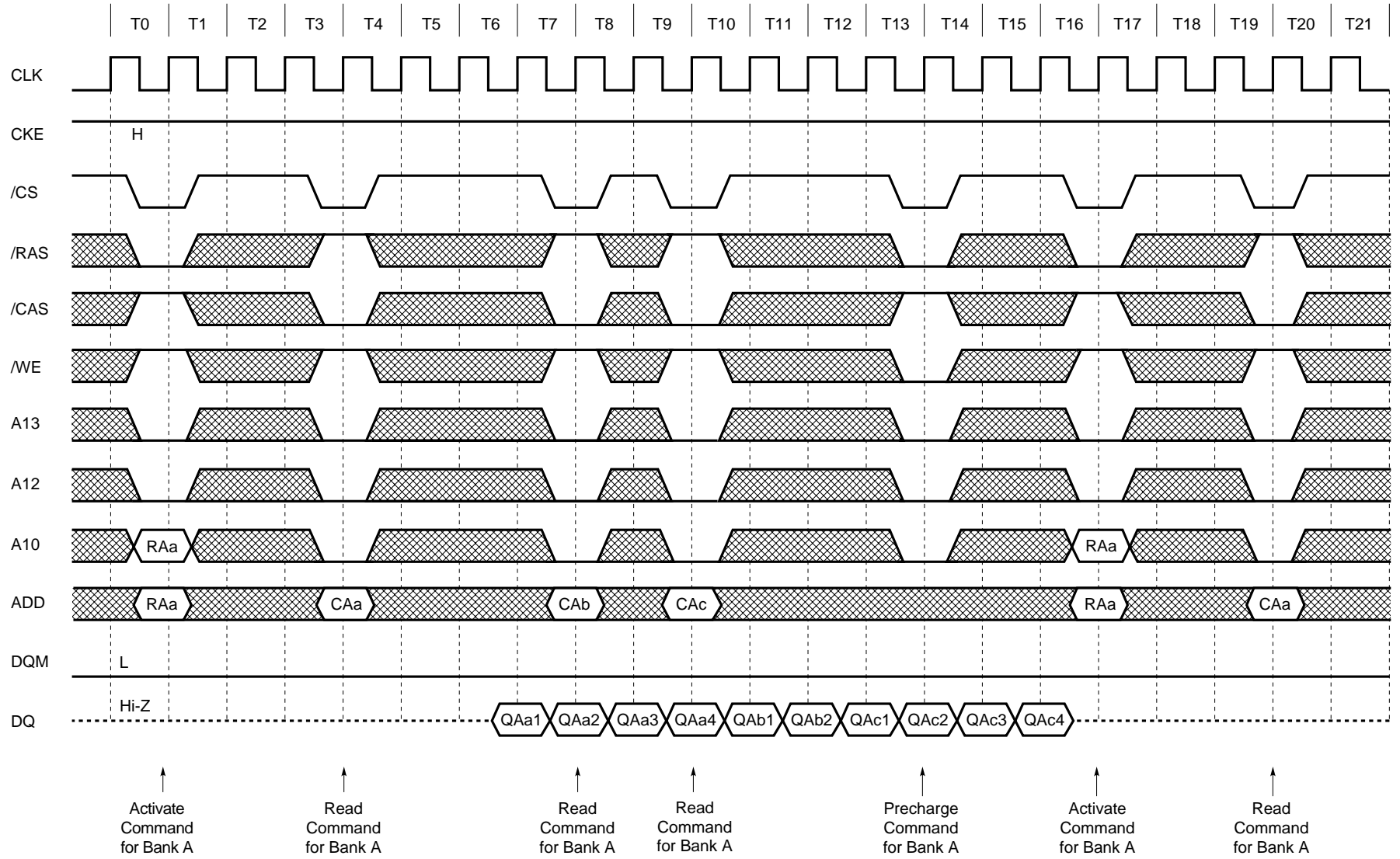

13.13 Random Column Write (Page with Same Bank) (Burst Length = 4, /CAS Latency = 3)

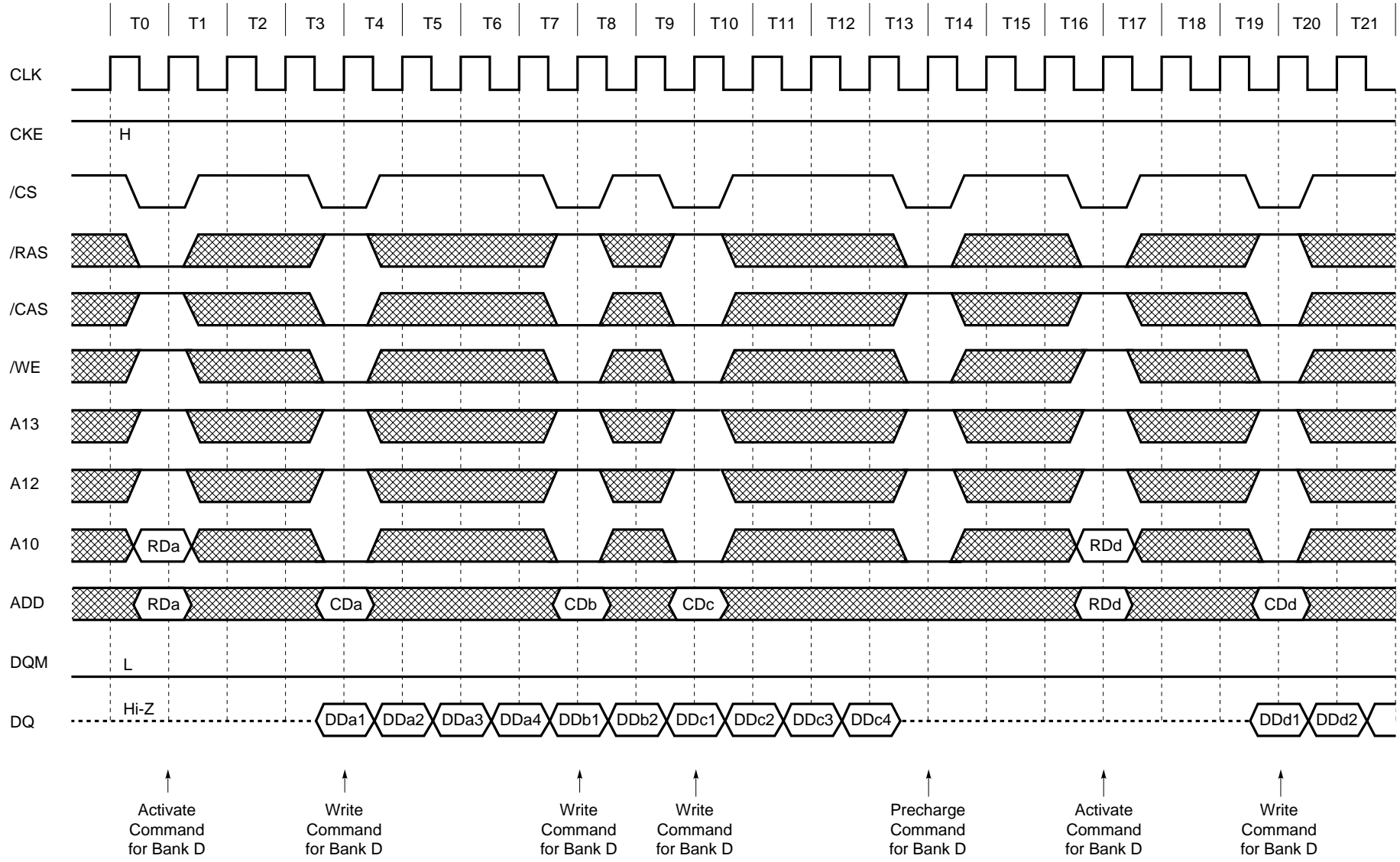

Data Sheet E0150N10

13.14 Random Row Read (Ping-Pong Banks) (Burst Length = 8, /CAS Latency = 3)

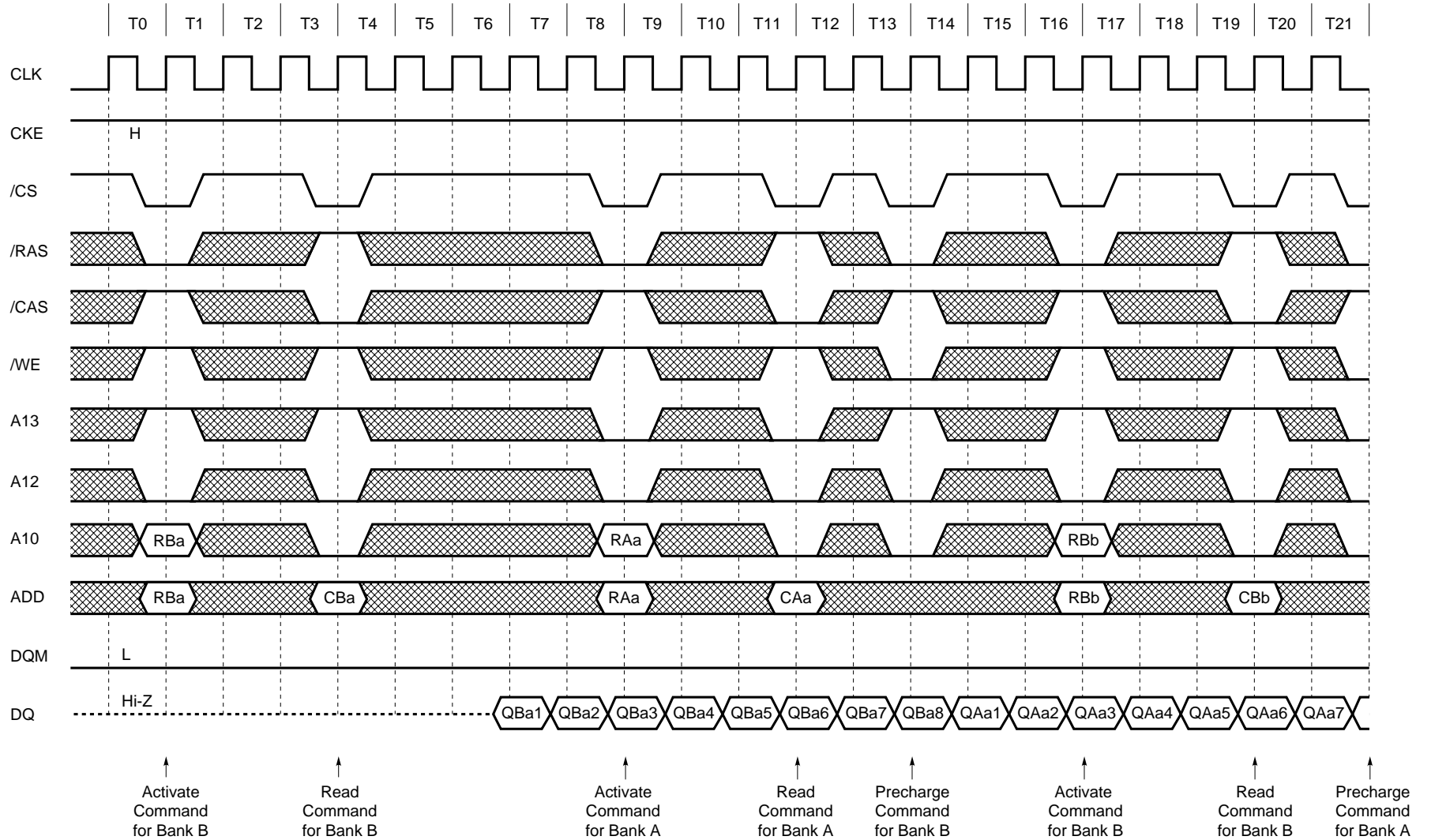

Data Sheet E0150N10

13.15 Random Row Write (Ping-Pong Banks) (Burst Length = 8, /CAS Latency = 3)

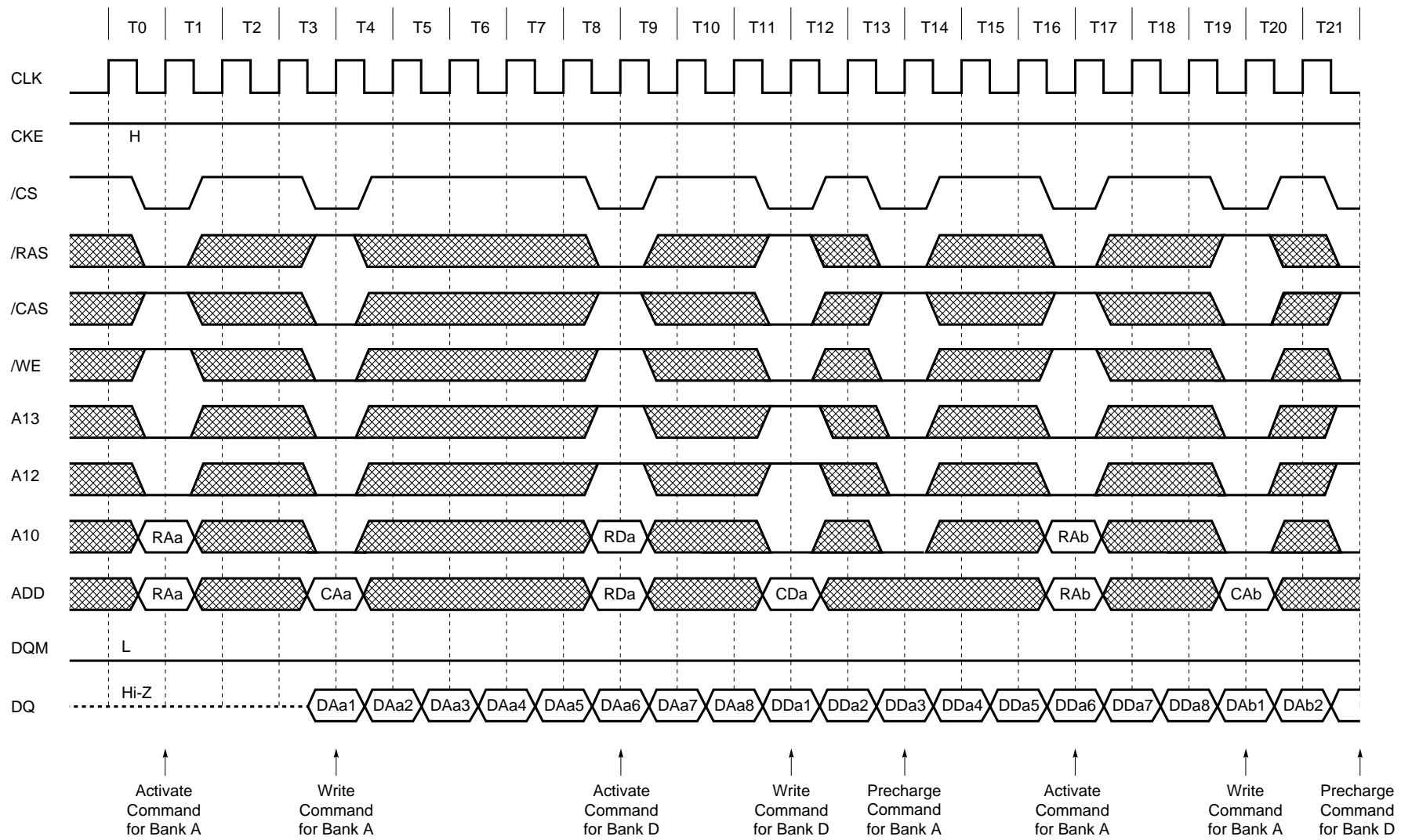

Data Sheet E0150N10

13.16 Read and Write (Burst Length = 4, /CAS Latency = 3)

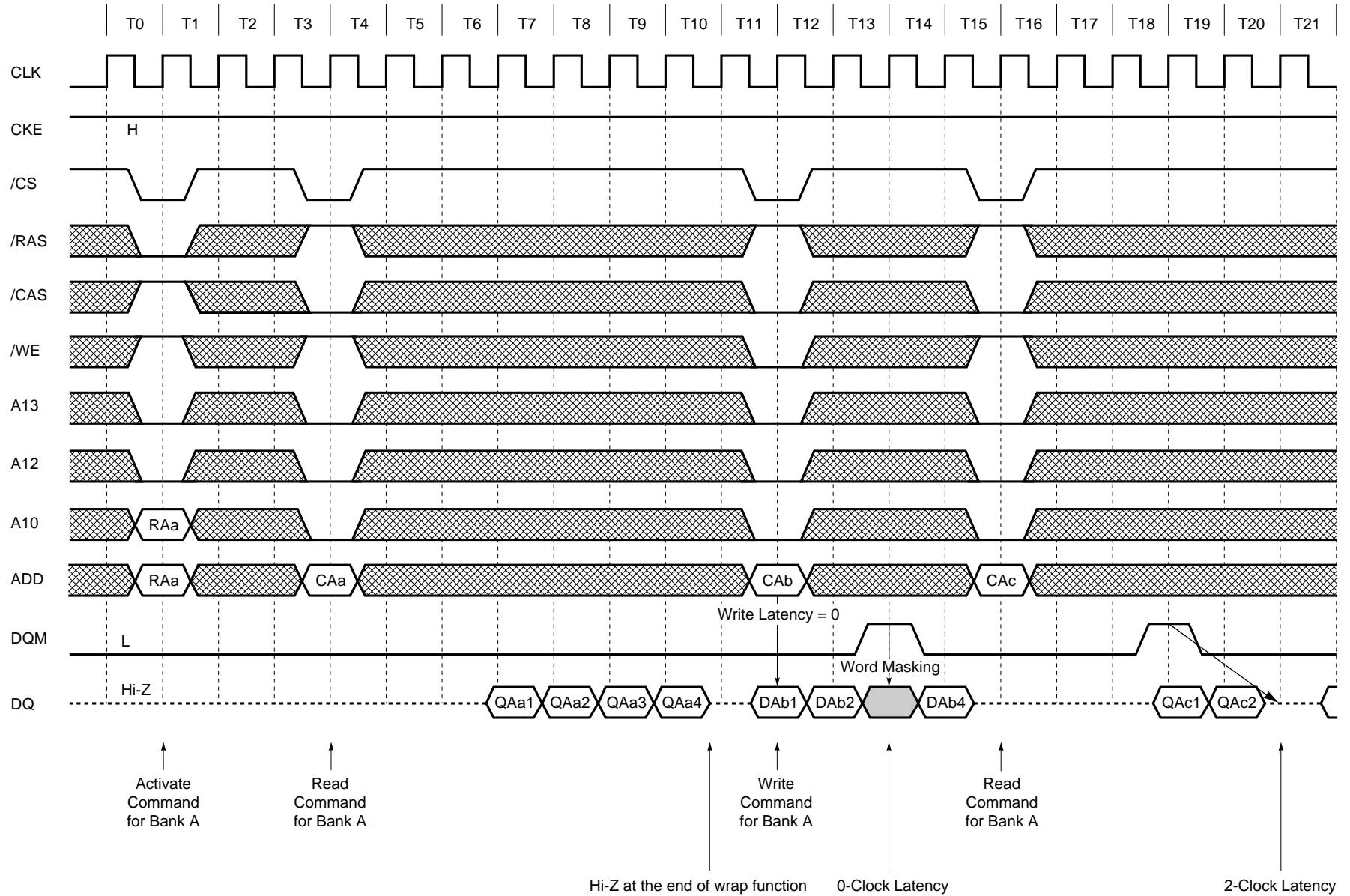

13.17 Interleaved Column Read Cycle (Burst Length = 4, /CAS Latency = 3)

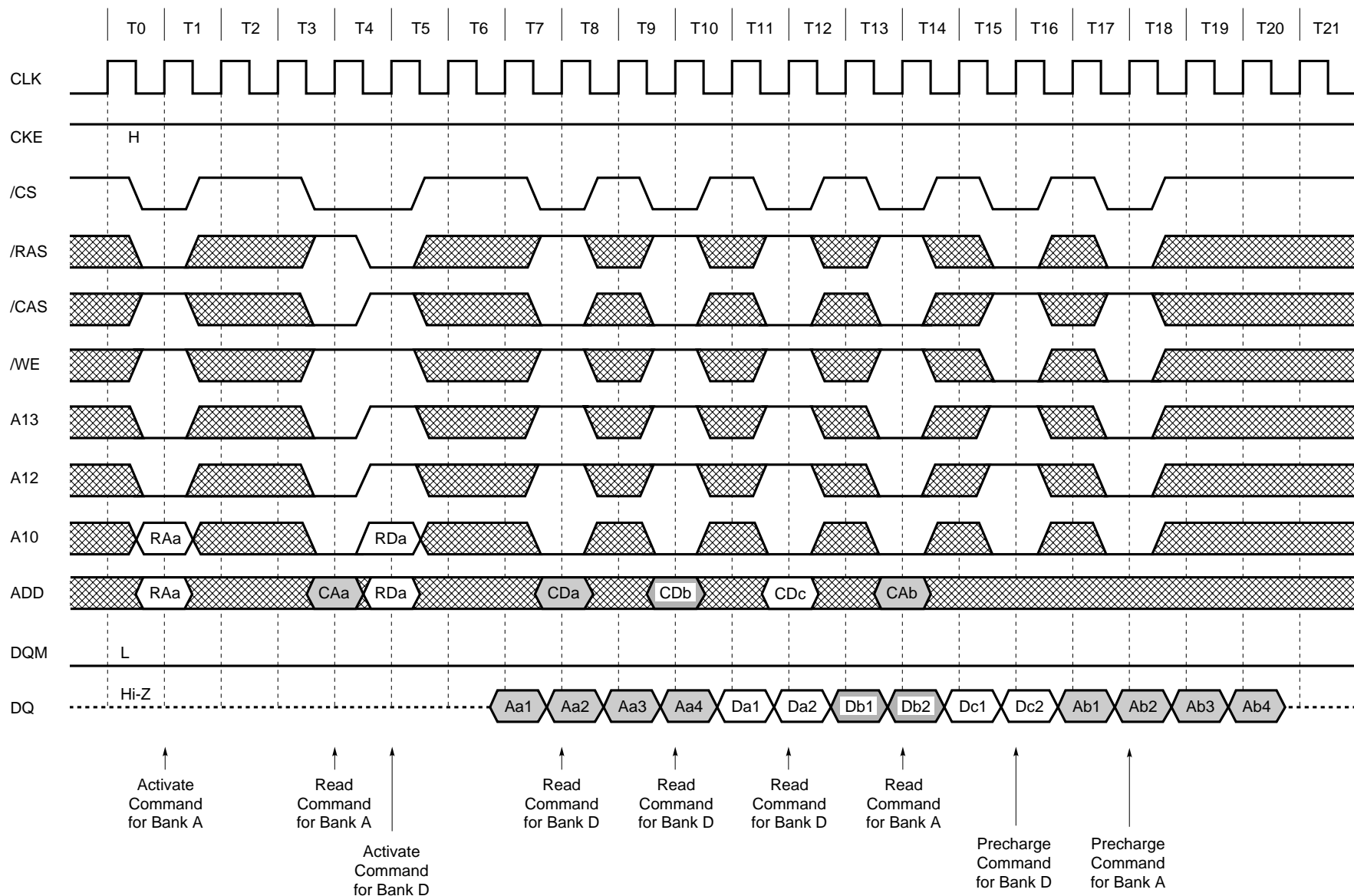

13.18 Interleaved Column Write Cycle (Burst Length = 4, /CAS Latency = 3)

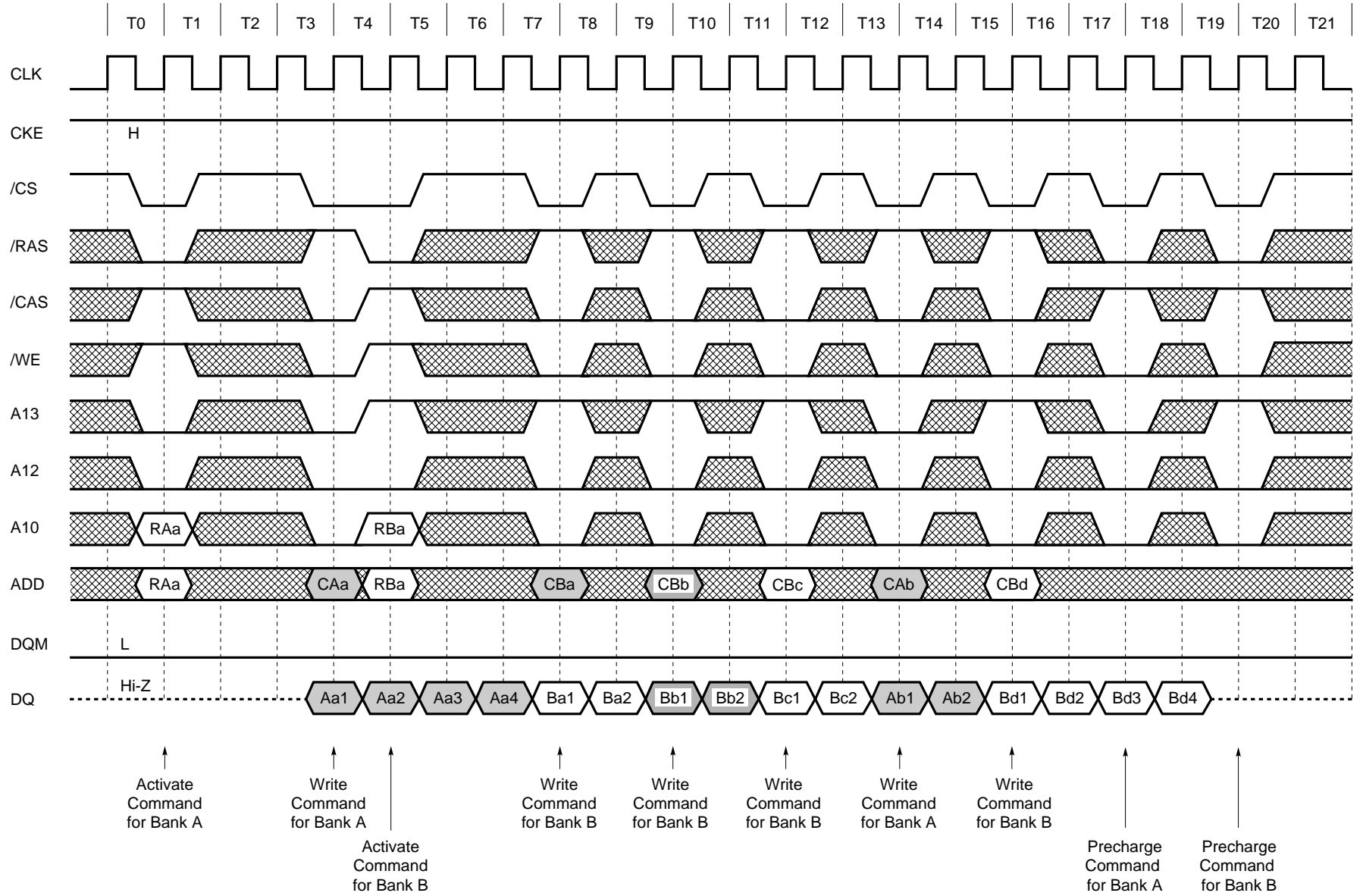

Data Sheet E0150N10

13.19 Auto Precharge after Read Burst (Burst Length = 4, /CAS Latency = 3)

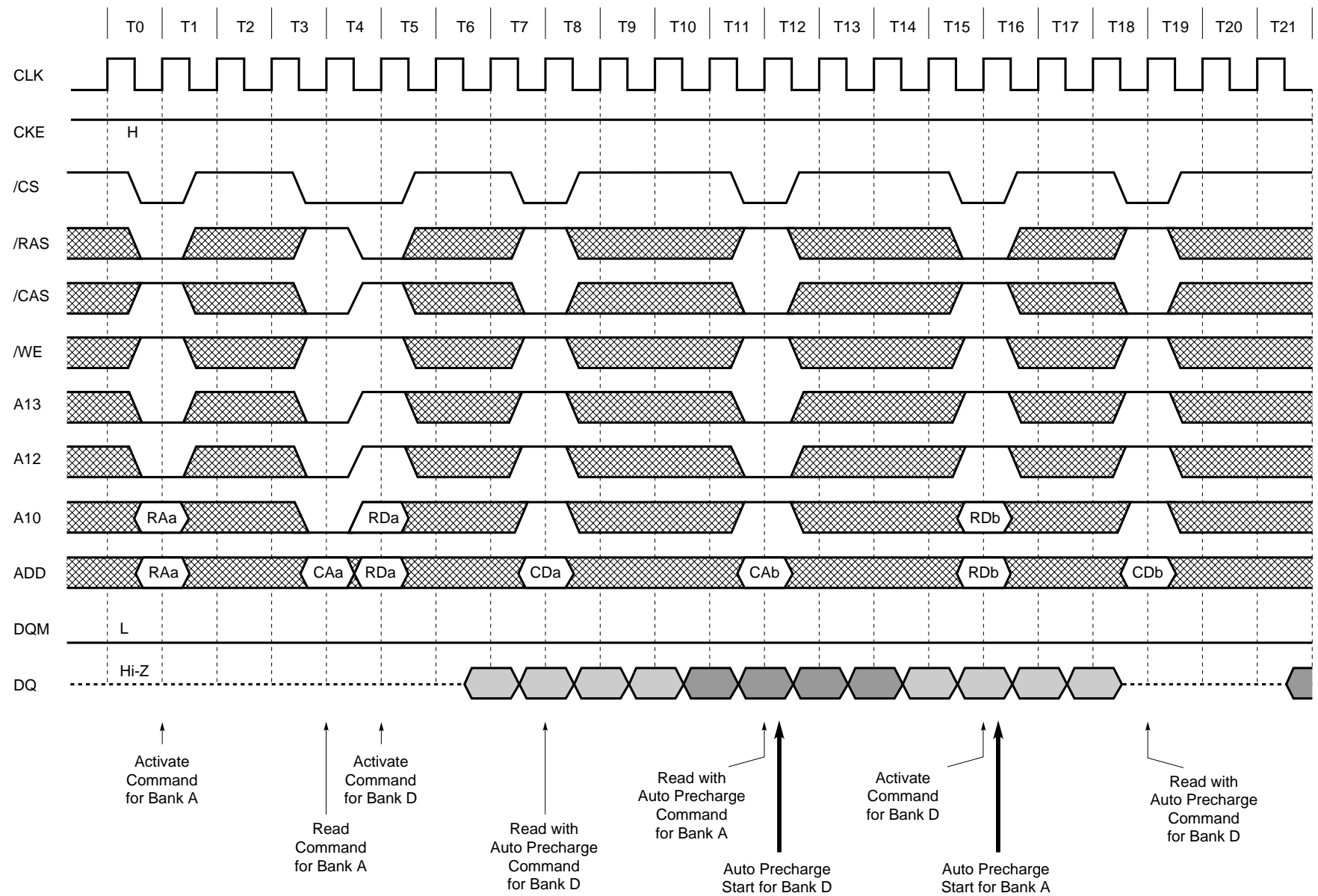

Data Sheet E0150N10

13.20 Auto Precharge after Write Burst (Burst Length = 4, /CAS Latency = 3)

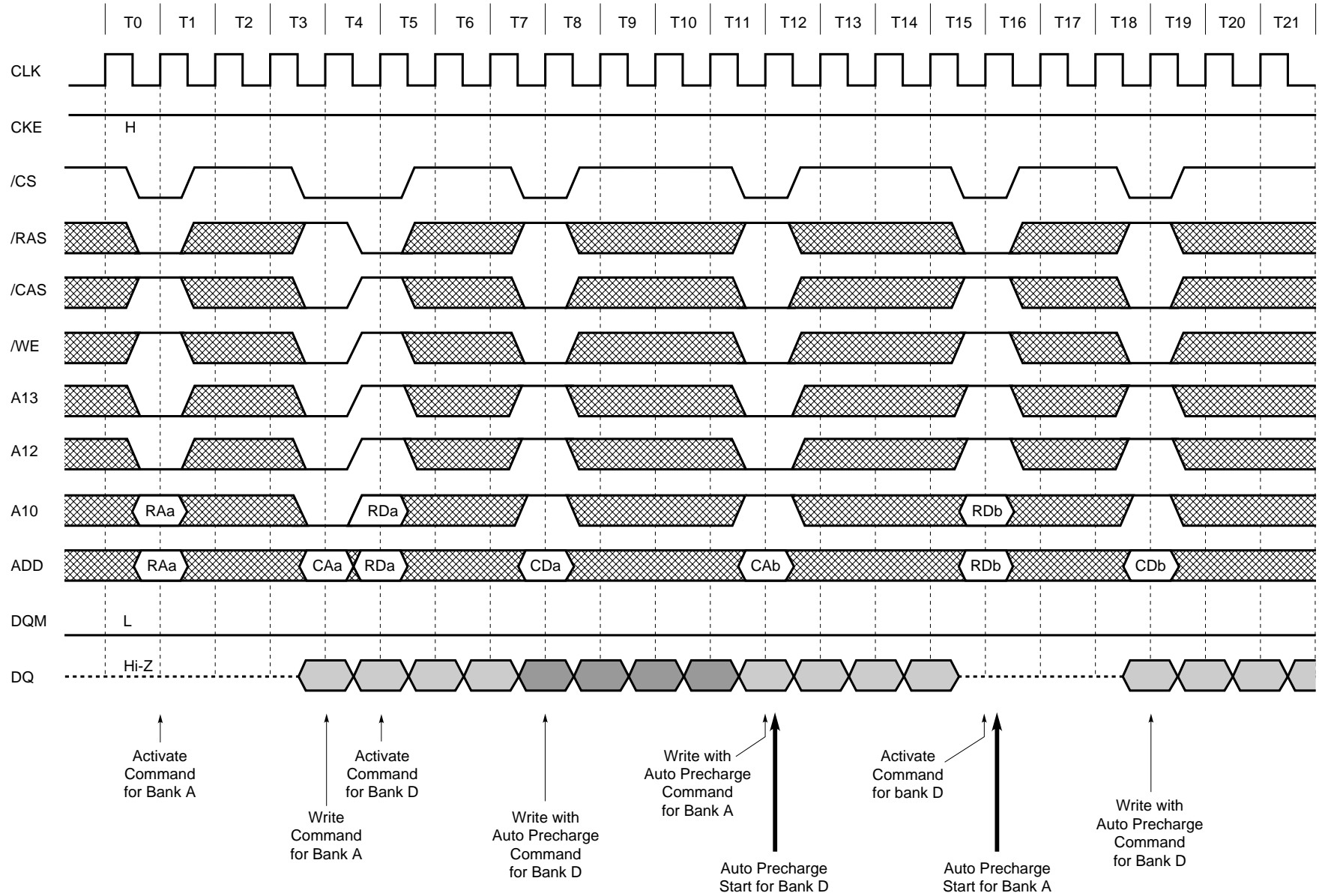

13.21 Full Page Read Cycle (/CAS latency = 3)

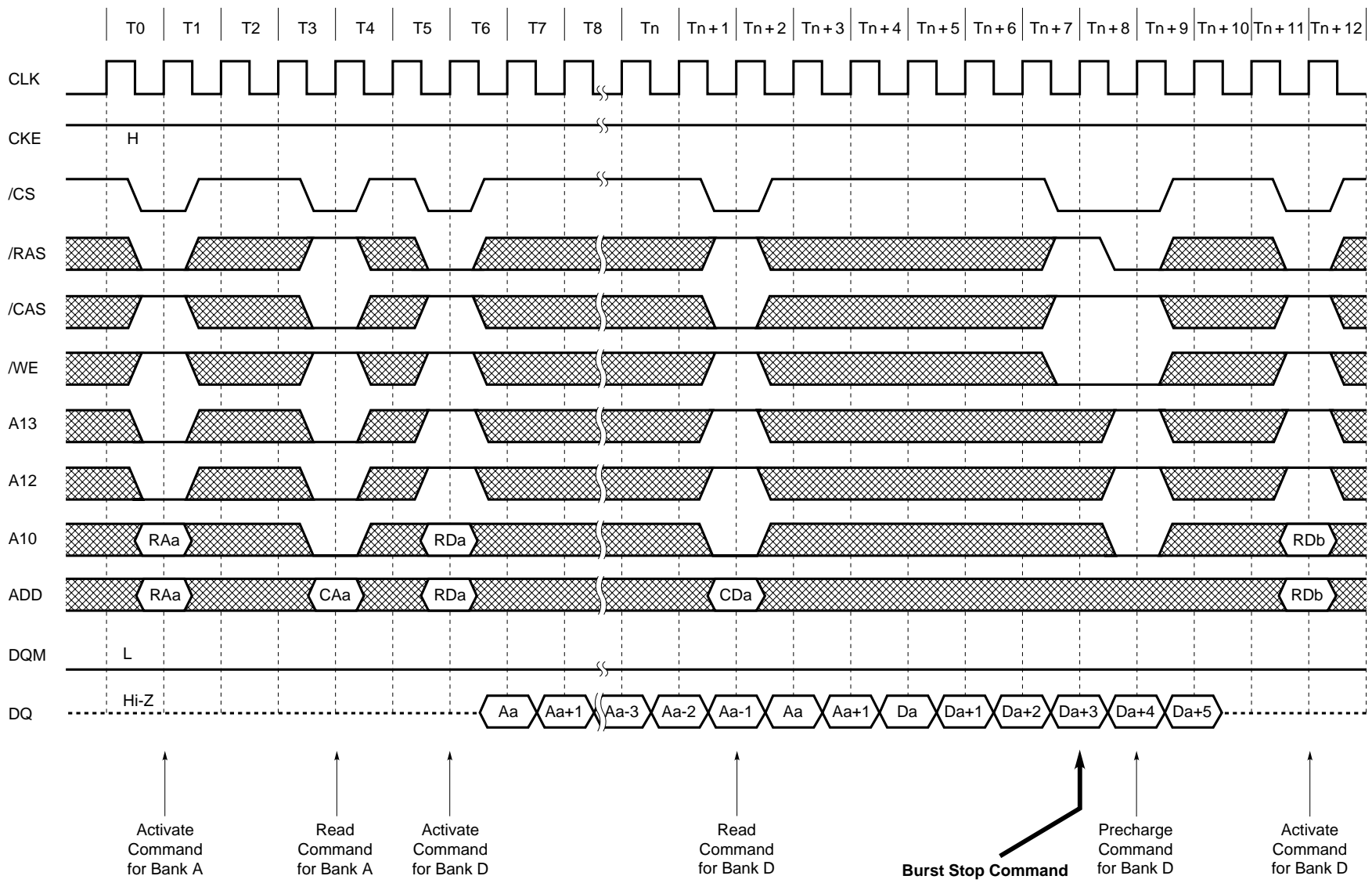

13.22 Full Page Write Cycle (/CAS Latency = 3)

Data Sheet E0150N10

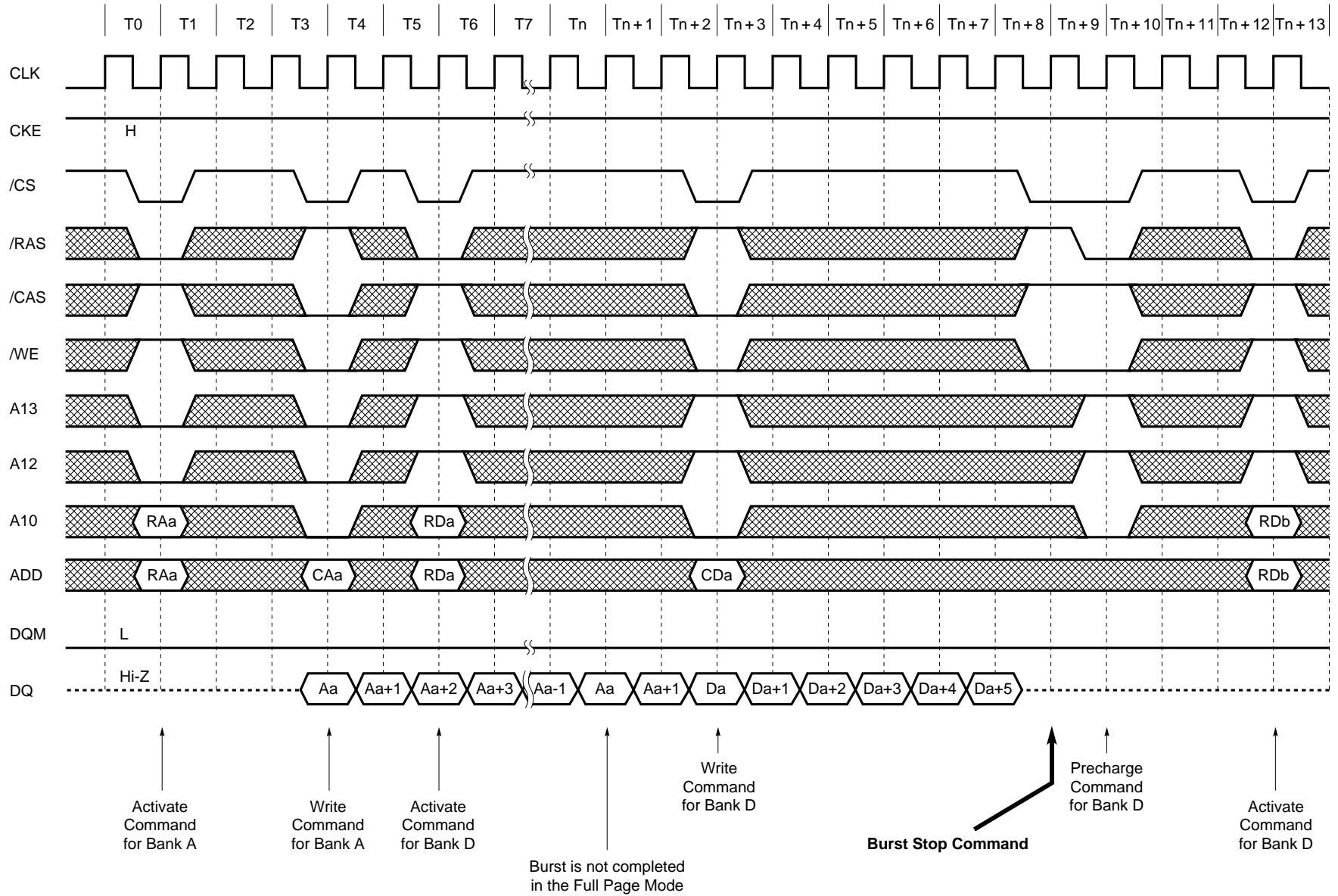

13.23 Byte Write Operation (Burst Length = 4, /CAS Latency = 3)

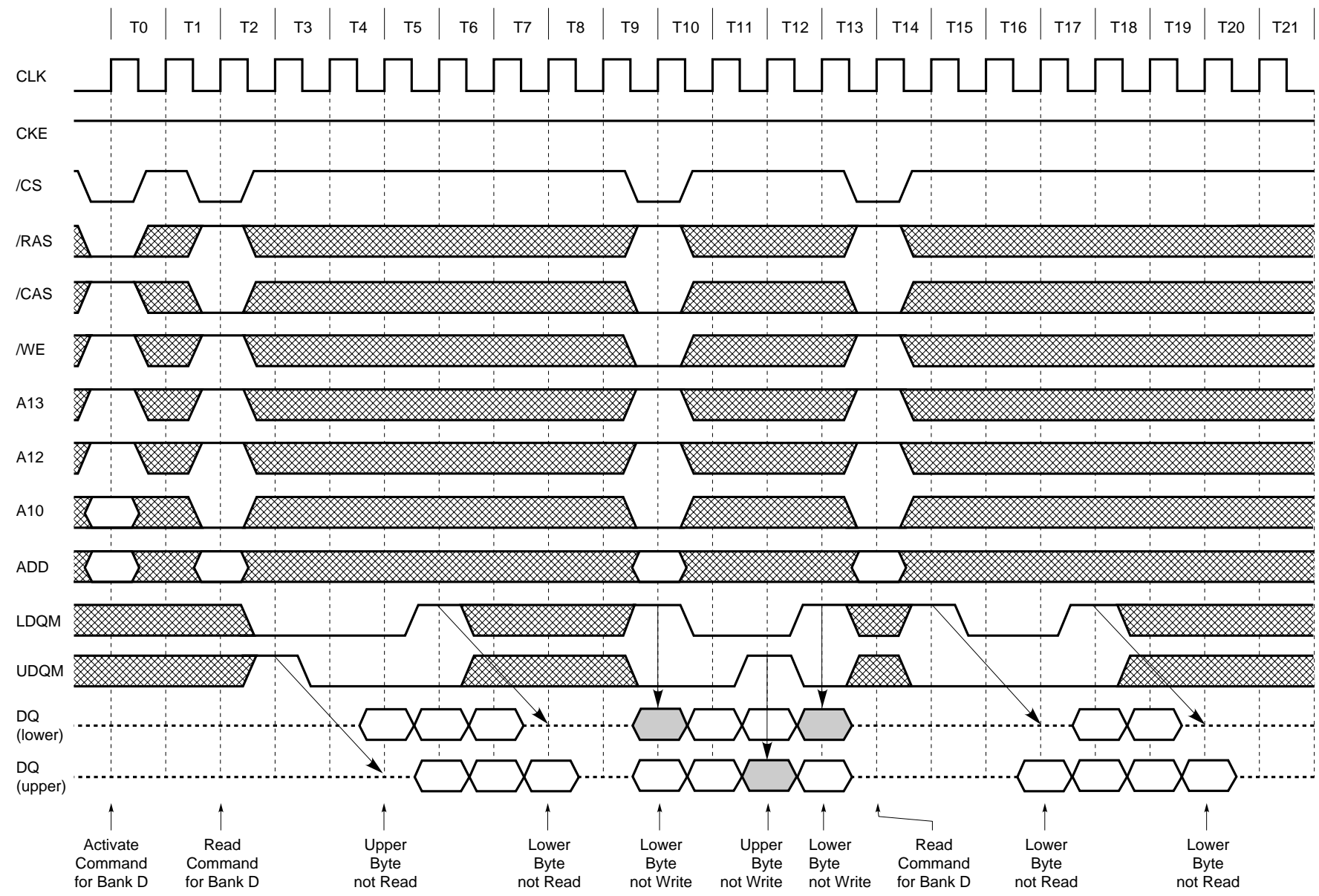

13.24 Burst Read and Single Write (Option) (Burst Length = 4, /CAS Latency = 3)

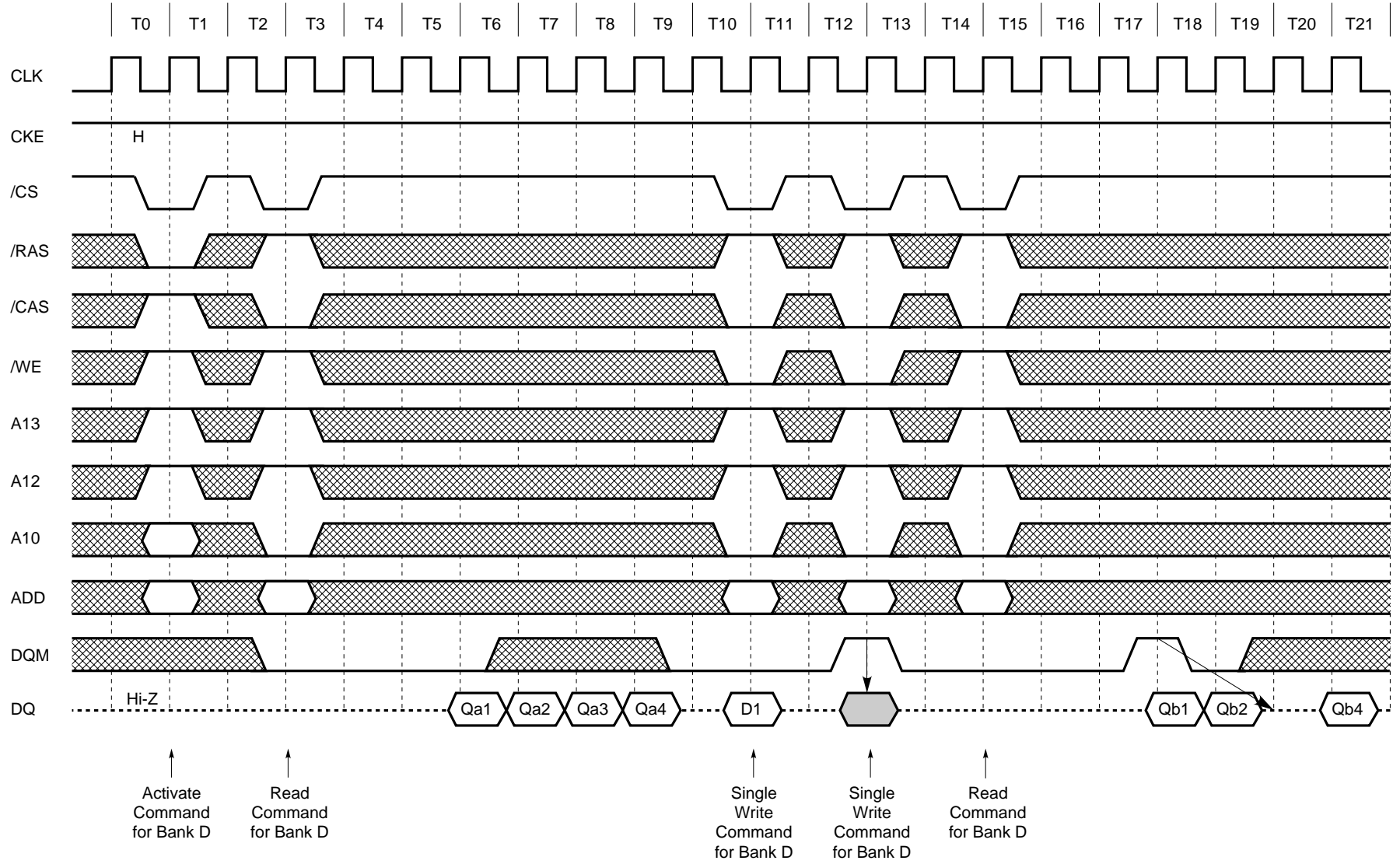

Data Sheet E0150N10

13.25 Full Page Random Column Read (Burst Length = Full Page, /CAS Latency = 3)

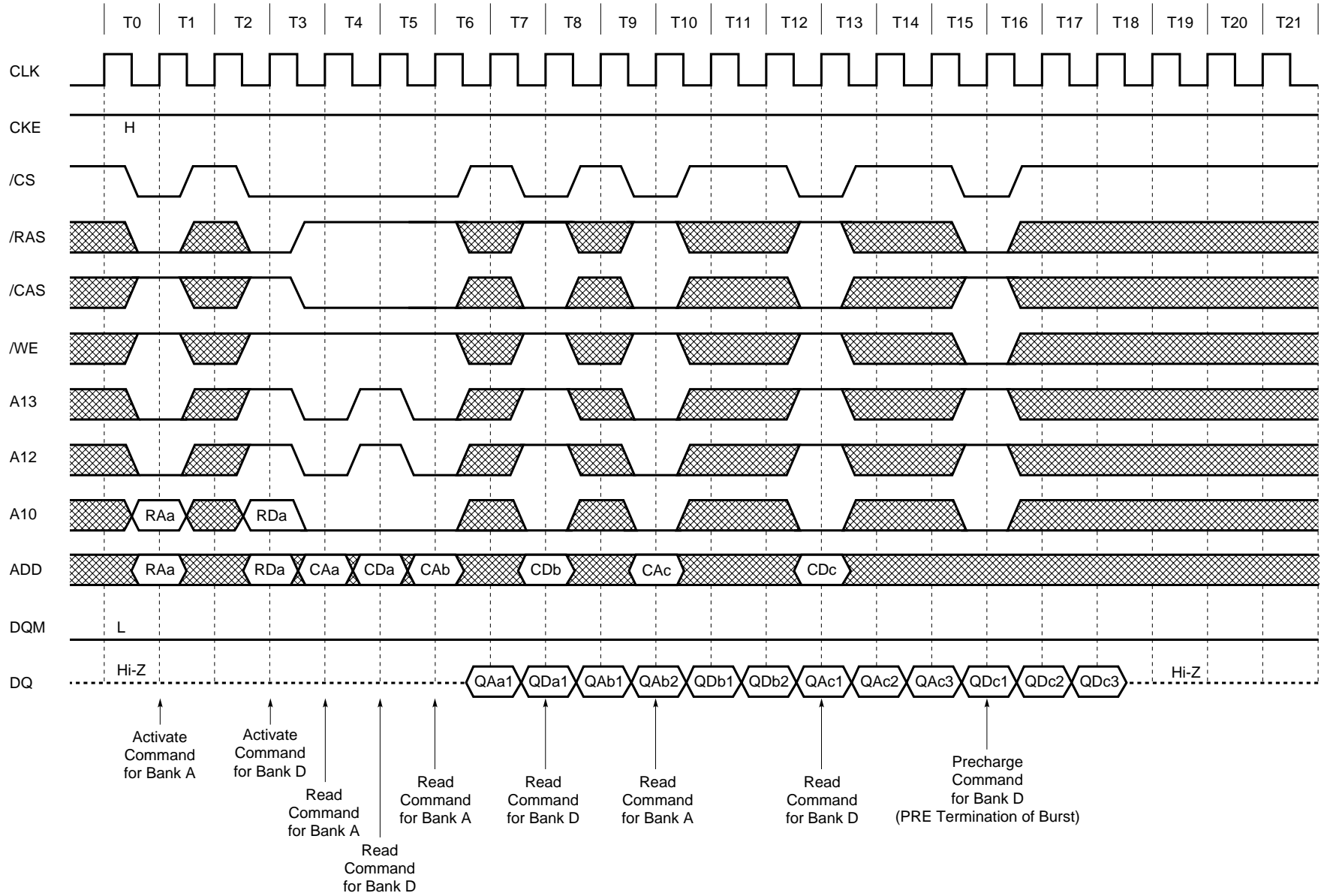

13.26 Full Page Random Column Write (Burst Length = Full Page, /CAS Latency = 3)

Data Sheet E0150N10

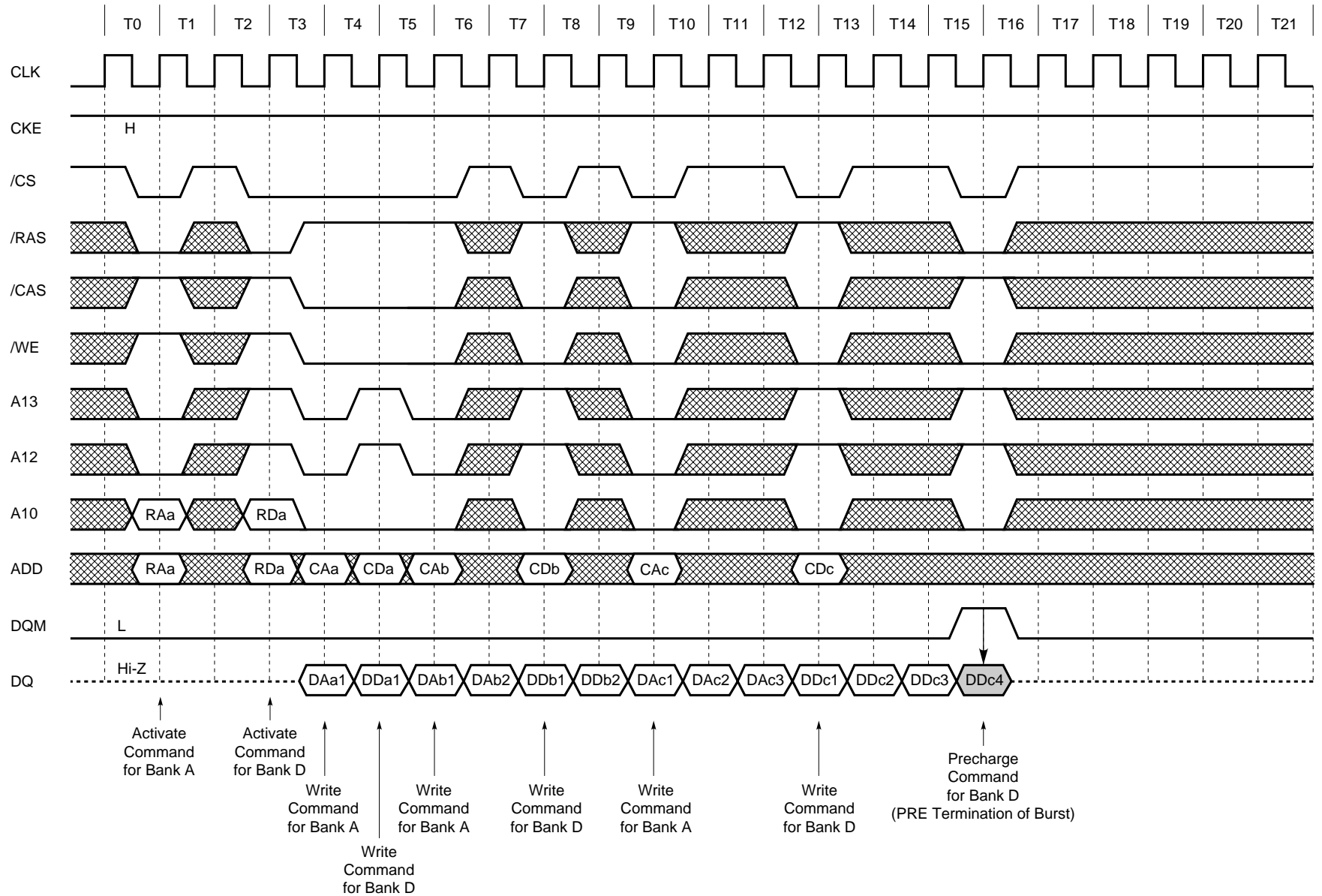

13.27 PRE (Precharge) Termination of Burst (Burst Length = 8, /CAS Latency = 3)

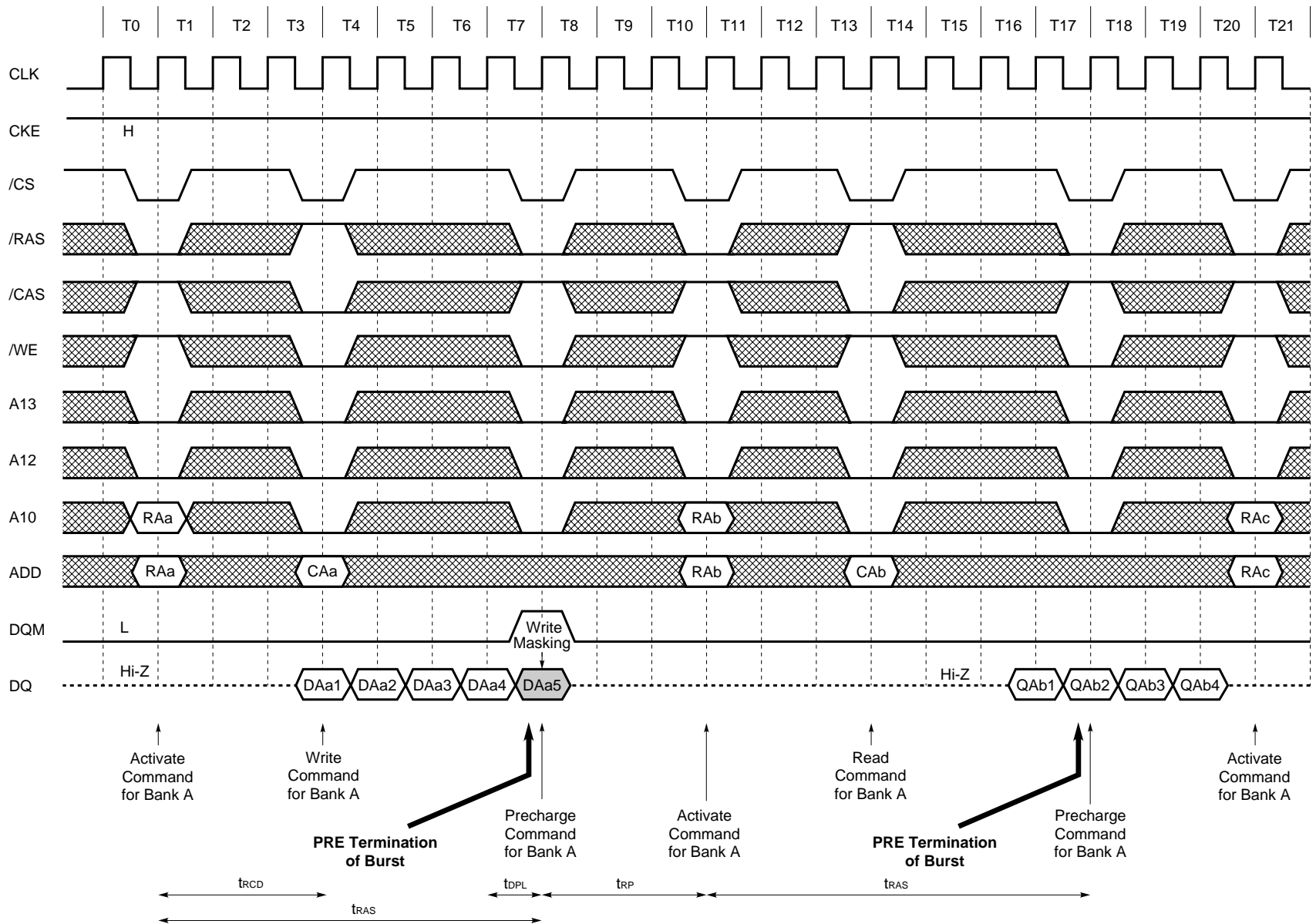

Data Sheet E0150N10

14. Package Drawing

54-PIN PLASTIC TSOP (II) (10.16 mm (400))

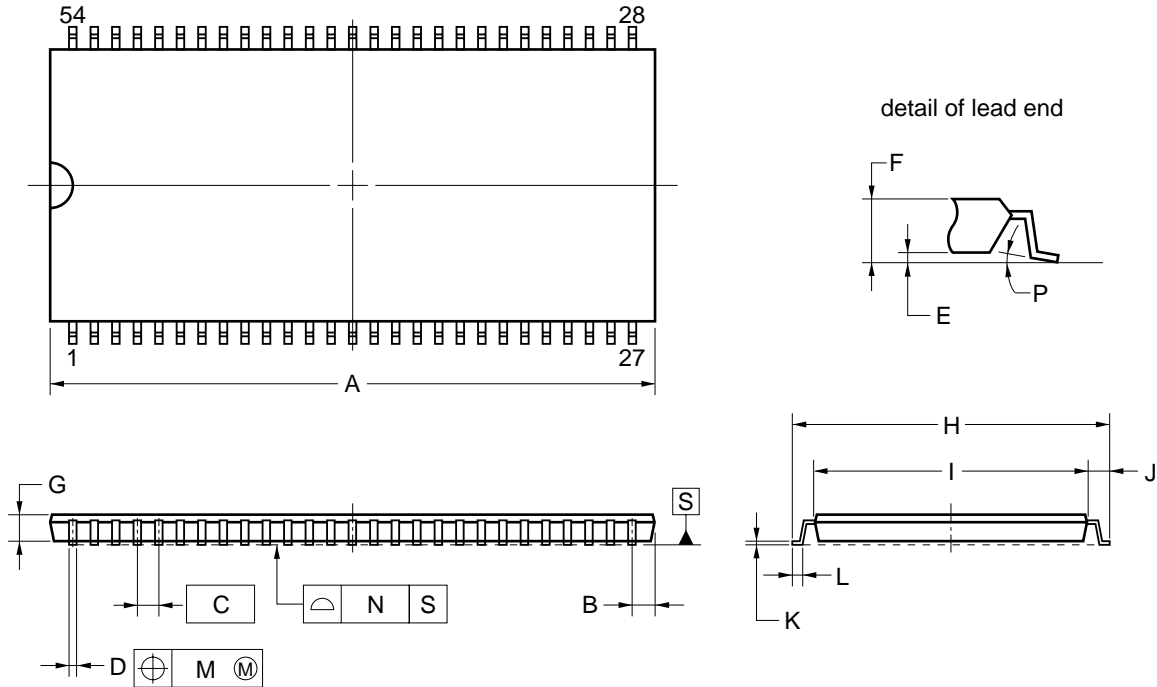

NOTES

1. Each lead centerline is located within 0.13 mm of its true position (T.P.) at maximum material condition.
2. Dimension "A" does not include mold flash, protrusions or gate burrs. Mold flash, protrusions or gate burrs shall not exceed 0.15 mm per side.

ITEM	MILLIMETERS
A	22.22±0.05
B	0.91 MAX.
C	0.80 (T.P.)
D	0.32 ^{+0.08} _{-0.07}
E	0.10±0.05
F	1.1±0.1
G	1.00
H	11.76±0.20
I	10.16±0.10
J	0.80±0.20
K	0.145 ^{+0.025} _{-0.015}
L	0.50±0.10
M	0.13
N	0.10
P	3 ^{+7°} _{-3°}

S54G5-80-9JF-2

15. Recommended Soldering Condition

Please consult with our sales offices for soldering conditions of the μ PD4564xxx.

Type of Surface Mount Device

μ PD4564xxxG5: 54-pin Plastic TSOP (II) (10.16mm (400))

16. Revision History

Edition / Date	Page		Description	
	This edition	Previous edition	Type of revision	Location
NEC Corporation (M14437E)				
1st edition / July 1999	–	–	–	–
2nd edition / January 2000	p.34	p.34	Modification	Icc2PS
	p.35	p.35	Modification	AC Characteristics Test Conditions
	p.37	p.37	Modification	t _{RP} , t _{RCD}
	p.37, 41	p.37, 41	Modification	t _{DPL}
	p.66	p.66	Modification	Package Drawing
3rd edition / January 2000	p.37	p.37	Modification	t _{DAL3}
Elpida Memory, Inc. (E0150N)				
Ver.1.0 / August. 2001	–	–	–	Republished by Elpida Memory, Inc.

NOTES FOR CMOS DEVICES**① PRECAUTION AGAINST ESD FOR MOS DEVICES**

Exposing the MOS devices to a strong electric field can cause destruction of the gate oxide and ultimately degrade the MOS devices operation. Steps must be taken to stop generation of static electricity as much as possible, and quickly dissipate it, when once it has occurred. Environmental control must be adequate. When it is dry, humidifier should be used. It is recommended to avoid using insulators that easily build static electricity. MOS devices must be stored and transported in an anti-static container, static shielding bag or conductive material. All test and measurement tools including work bench and floor should be grounded. The operator should be grounded using wrist strap. MOS devices must not be touched with bare hands. Similar precautions need to be taken for PW boards with semiconductor MOS devices on it.

② HANDLING OF UNUSED INPUT PINS FOR CMOS DEVICES

No connection for CMOS devices input pins can be a cause of malfunction. If no connection is provided to the input pins, it is possible that an internal input level may be generated due to noise, etc., hence causing malfunction. CMOS devices behave differently than Bipolar or NMOS devices. Input levels of CMOS devices must be fixed high or low by using a pull-up or pull-down circuitry. Each unused pin should be connected to V_{DD} or GND with a resistor, if it is considered to have a possibility of being an output pin. The unused pins must be handled in accordance with the related specifications.

③ STATUS BEFORE INITIALIZATION OF MOS DEVICES

Power-on does not necessarily define initial status of MOS devices. Production process of MOS does not define the initial operation status of the device. Immediately after the power source is turned ON, the MOS devices with reset function have not yet been initialized. Hence, power-on does not guarantee output pin levels, I/O settings or contents of registers. MOS devices are not initialized until the reset signal is received. Reset operation must be executed immediately after power-on for MOS devices having reset function.

CME0107

The information in this document is subject to change without notice. Before using this document, confirm that this is the latest version.

No part of this document may be copied or reproduced in any form or by any means without the prior written consent of Elpida Memory, Inc.

Elpida Memory, Inc. does not assume any liability for infringement of any intellectual property rights (including but not limited to patents, copyrights, and circuit layout licenses) of Elpida Memory, Inc. or third parties by or arising from the use of the products or information listed in this document. No license, express, implied or otherwise, is granted under any patents, copyrights or other intellectual property rights of Elpida Memory, Inc. or others.

Descriptions of circuits, software and other related information in this document are provided for illustrative purposes in semiconductor product operation and application examples. The incorporation of these circuits, software and information in the design of the customer's equipment shall be done under the full responsibility of the customer. Elpida Memory, Inc. assumes no responsibility for any losses incurred by customers or third parties arising from the use of these circuits, software and information.

[Product applications]

Elpida Memory, Inc. makes every attempt to ensure that its products are of high quality and reliability. However, users are instructed to contact Elpida Memory's sales office before using the product in aerospace, aeronautics, nuclear power, combustion control, transportation, traffic, safety equipment, medical equipment for life support, or other such application in which especially high quality and reliability is demanded or where its failure or malfunction may directly threaten human life or cause risk of bodily injury.

[Product usage]

Design your application so that the product is used within the ranges and conditions guaranteed by Elpida Memory, Inc., including the maximum ratings, operating supply voltage range, heat radiation characteristics, installation conditions and other related characteristics. Elpida Memory, Inc. bears no responsibility for failure or damage when the product is used beyond the guaranteed ranges and conditions. Even within the guaranteed ranges and conditions, consider normally foreseeable failure rates or failure modes in semiconductor devices and employ systemic measures such as fail-safes, so that the equipment incorporating Elpida Memory, Inc. products does not cause bodily injury, fire or other consequential damage due to the operation of the Elpida Memory, Inc. product.

[Usage environment]

This product is not designed to be resistant to electromagnetic waves or radiation. This product must be used in a non-condensing environment.

If you export the products or technology described in this document that are controlled by the Foreign Exchange and Foreign Trade Law of Japan, you must follow the necessary procedures in accordance with the relevant laws and regulations of Japan. Also, if you export products/technology controlled by U.S. export control regulations, or another country's export control laws or regulations, you must follow the necessary procedures in accordance with such laws or regulations.

If these products/technology are sold, leased, or transferred to a third party, or a third party is granted license to use these products, that third party must be made aware that they are responsible for compliance with the relevant laws and regulations.