

## *Part Number Decoder*

This document is intended to give customers understanding of the Elpida part numbering system. For detailed line-up about the individual products, please consult Elpida sales representatives.

# Elpida Products (Mono)

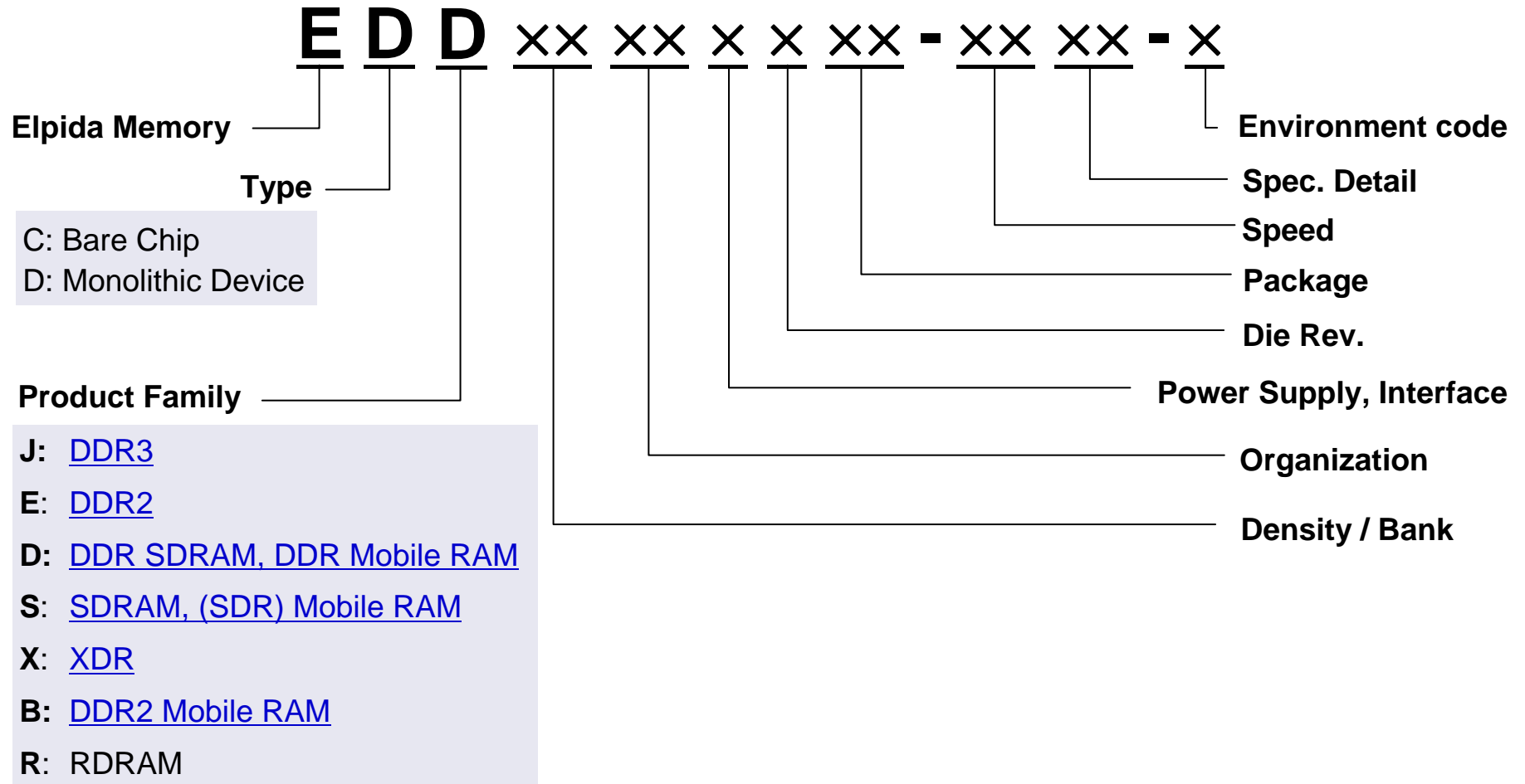

# Elpida Products (Module)

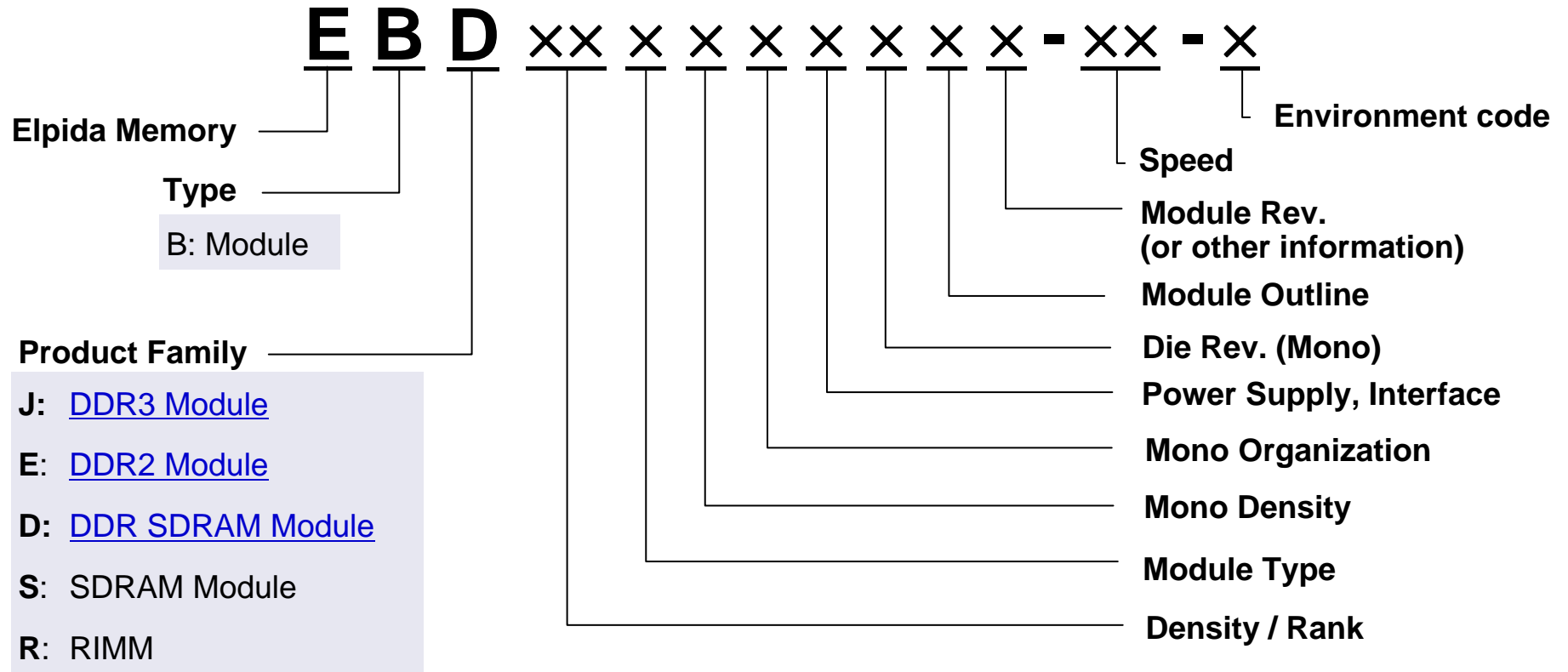

# DDR3

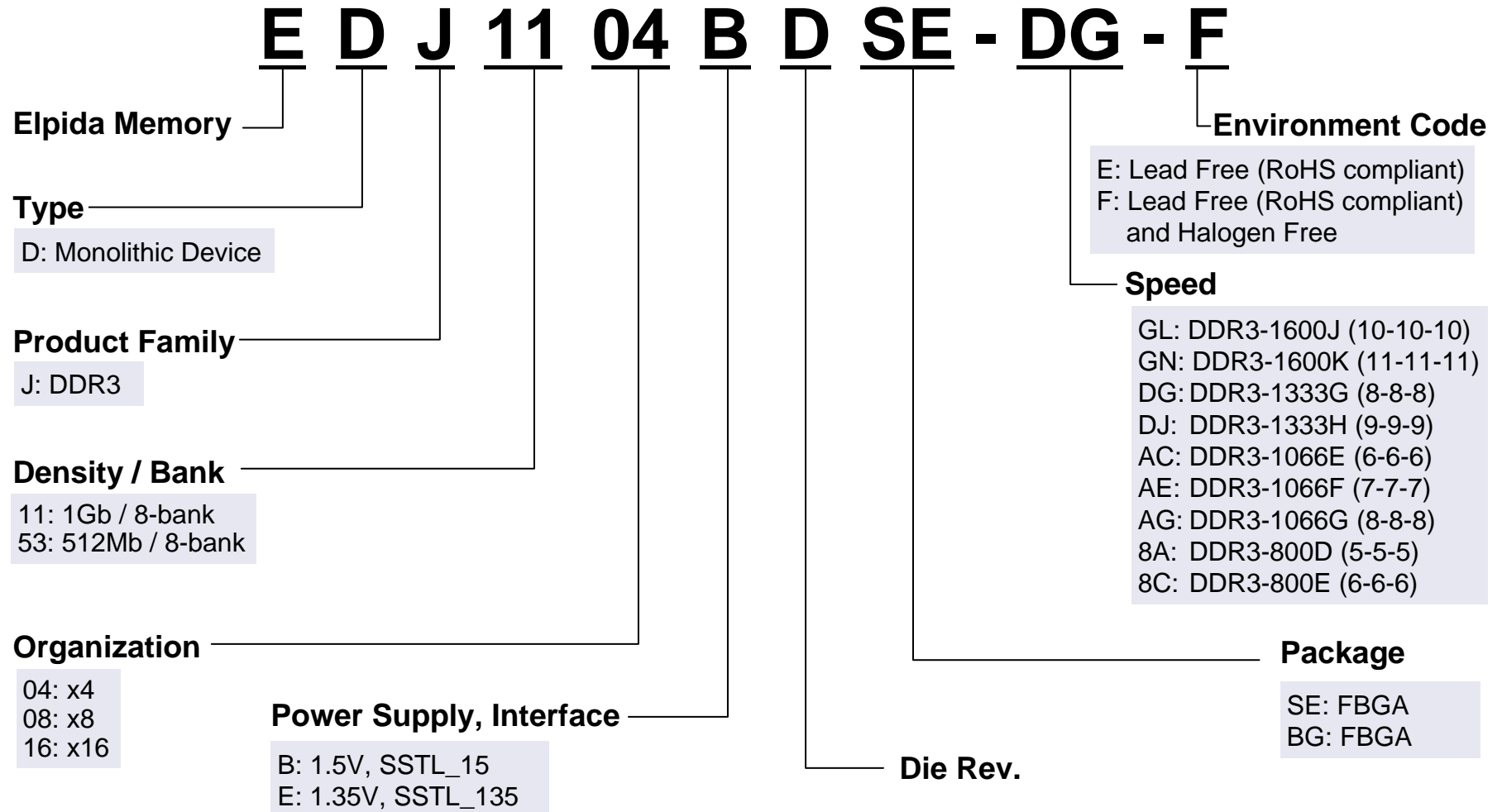

# DDR3 Module

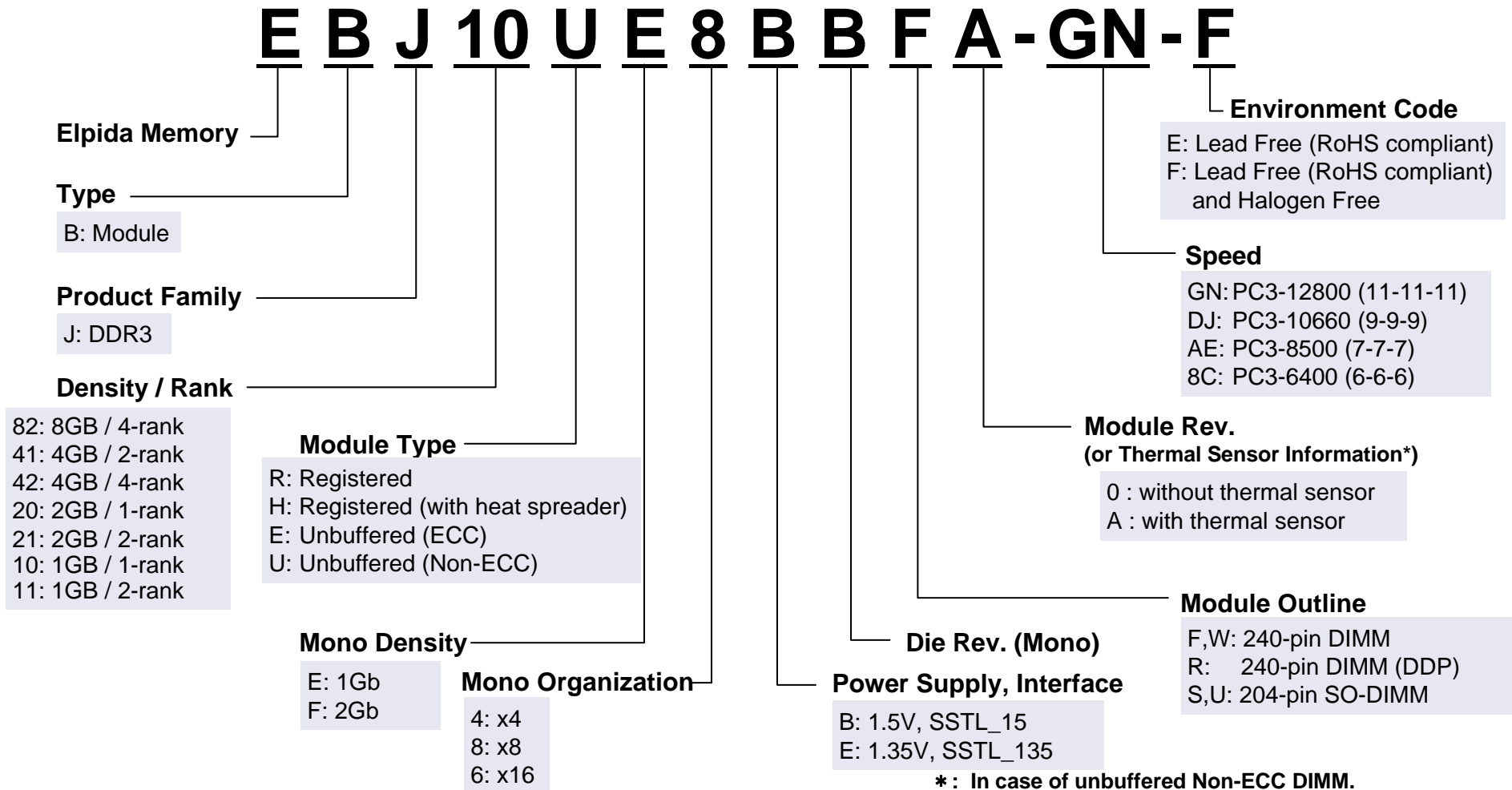

\*: In case of unbuffered Non-ECC DIMM.  
Both of "A" and "0" mean without thermal sensor.

# DDR2

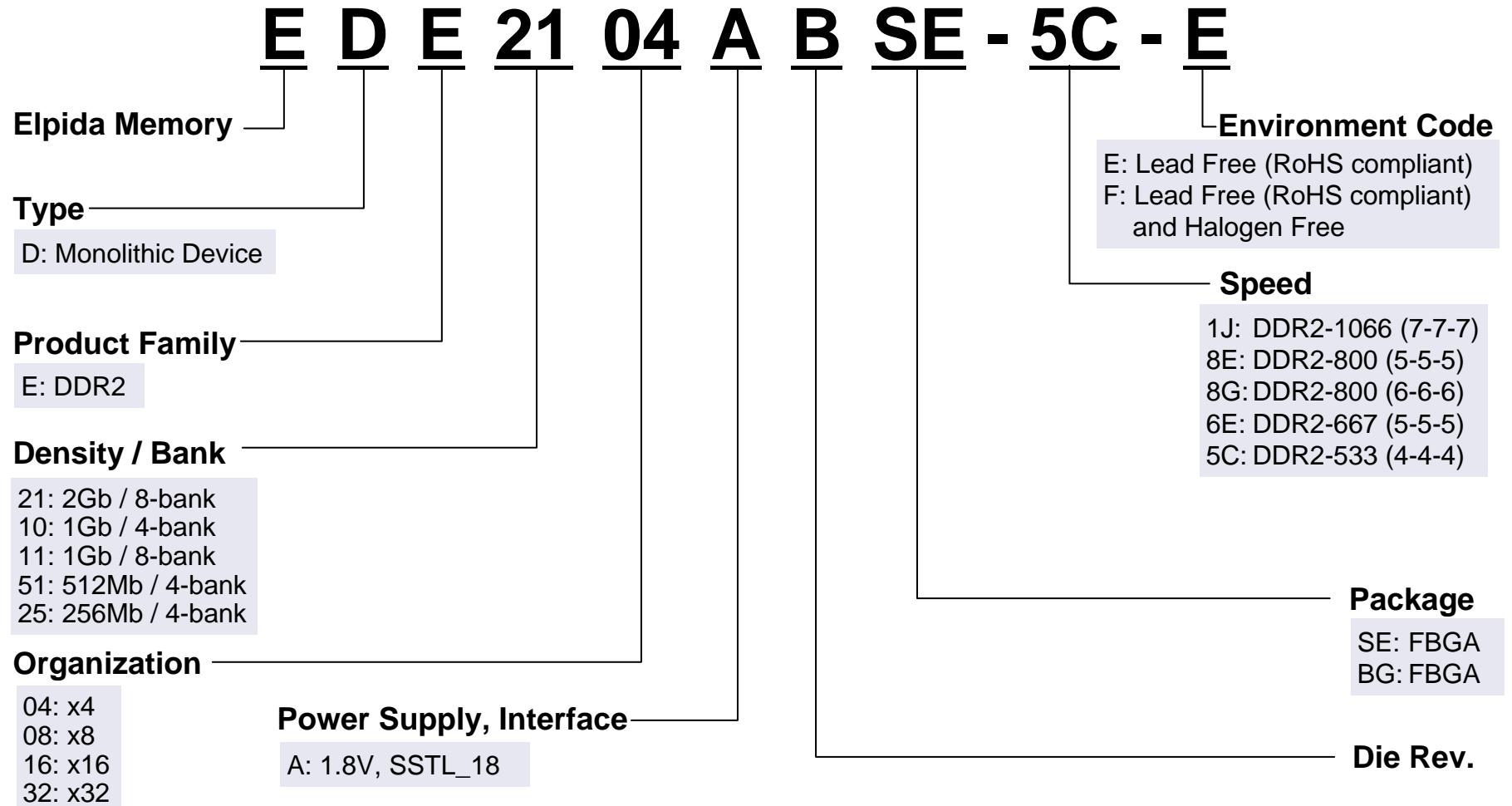

# DDR2 Module

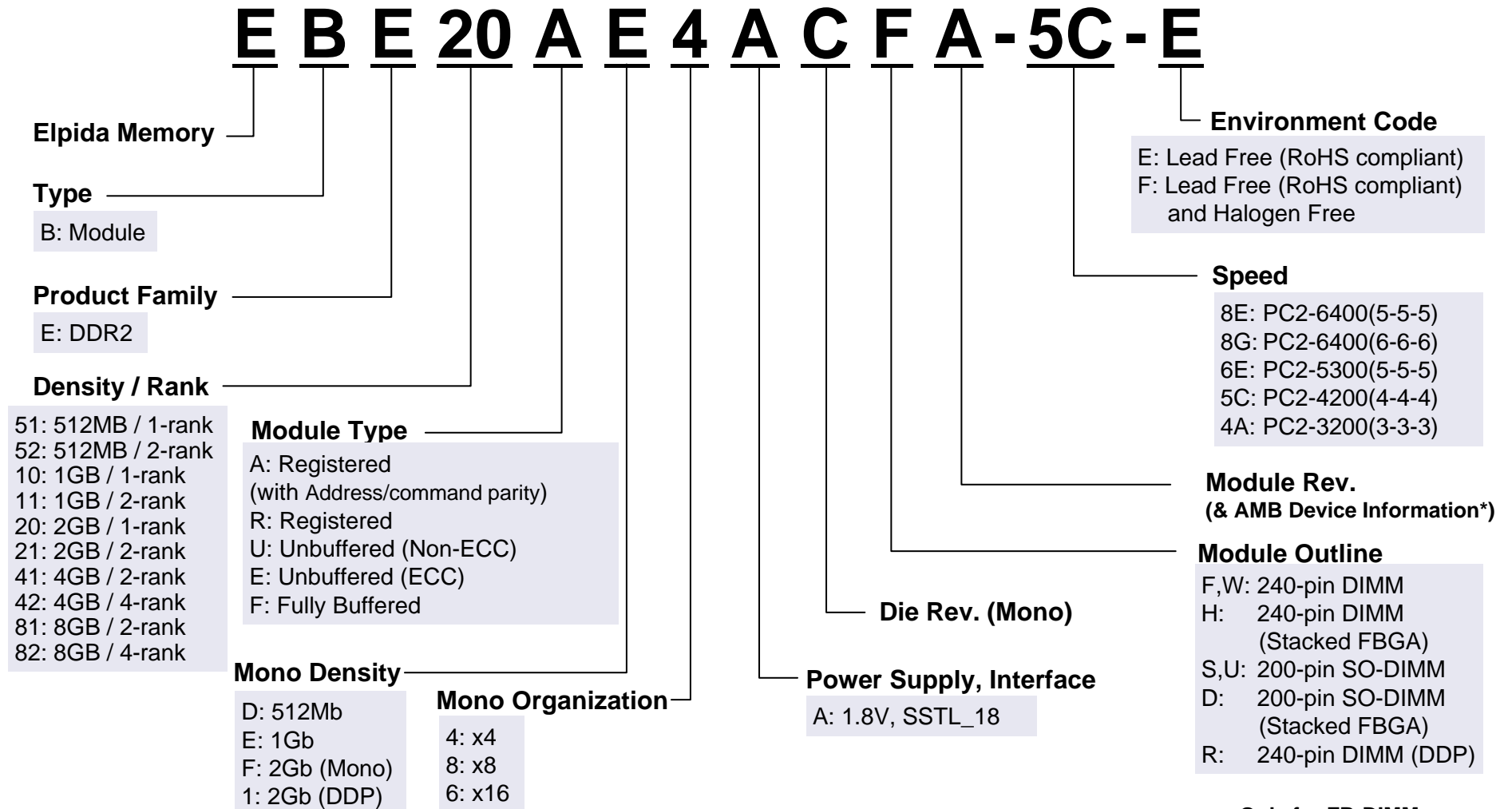

\*: Only for FB-DIMM

# DDR SDRAM, DDR Mobile RAM™

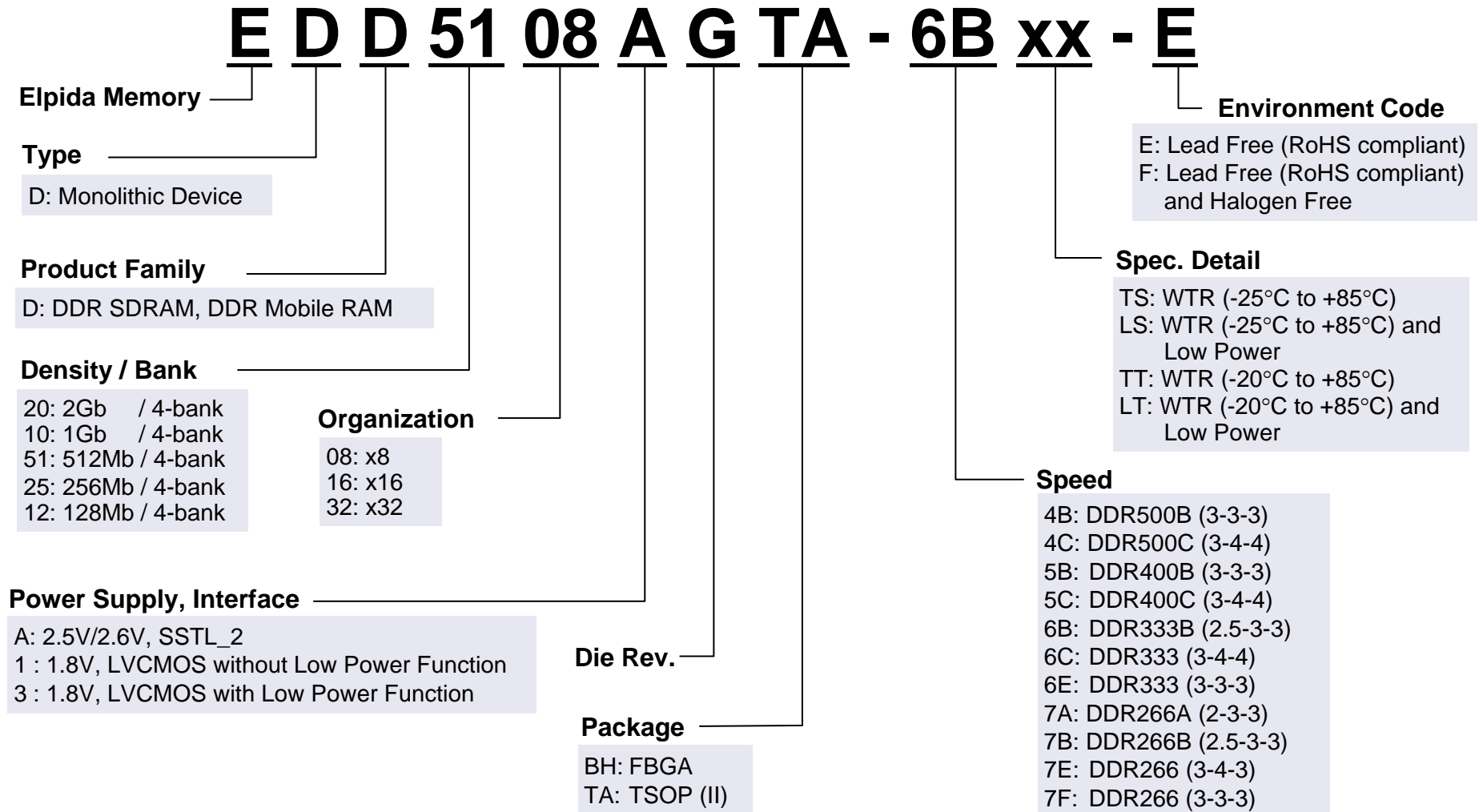

# DDR SDRAM Module

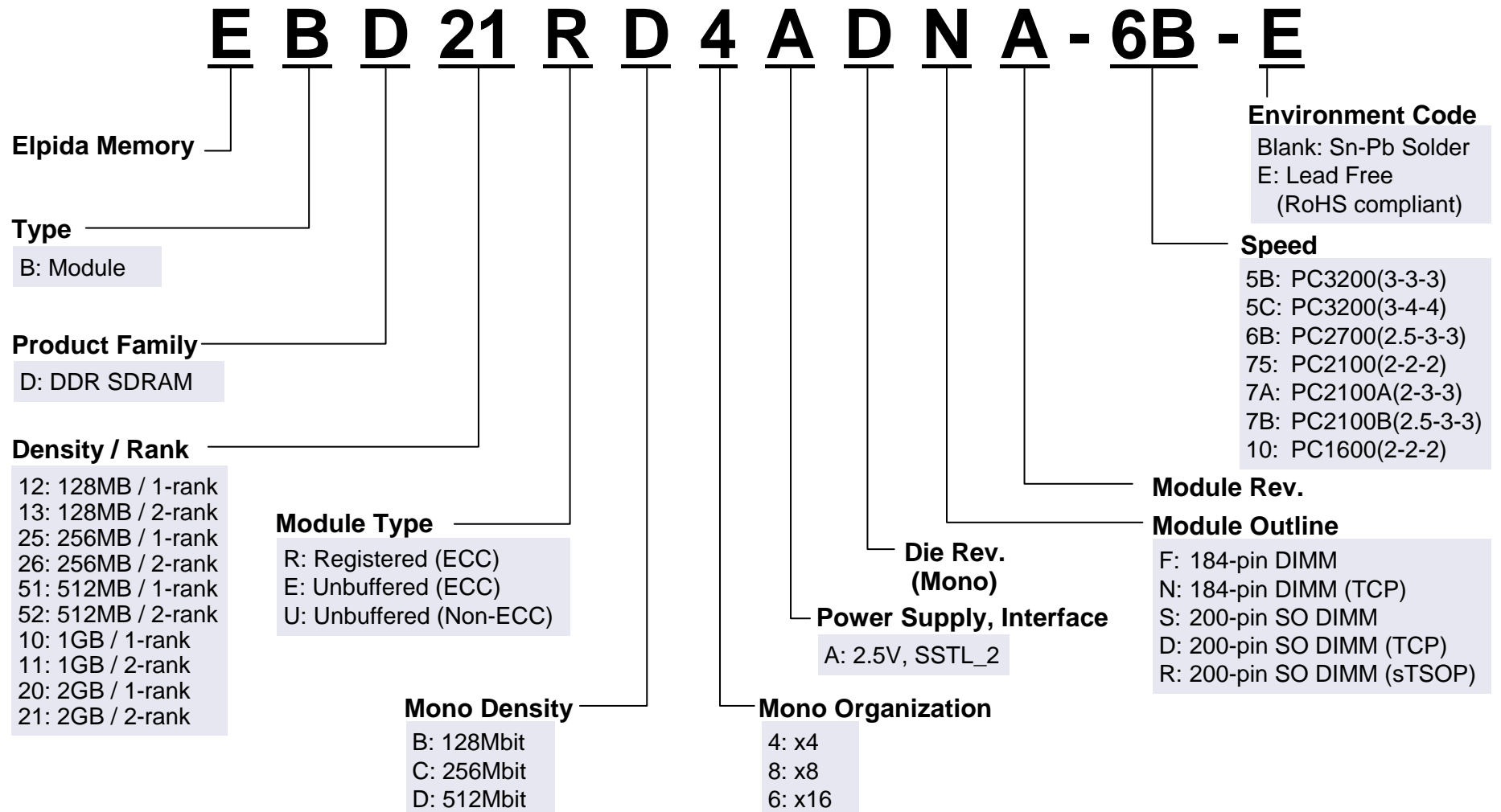

# SDRAM, Mobile RAM™

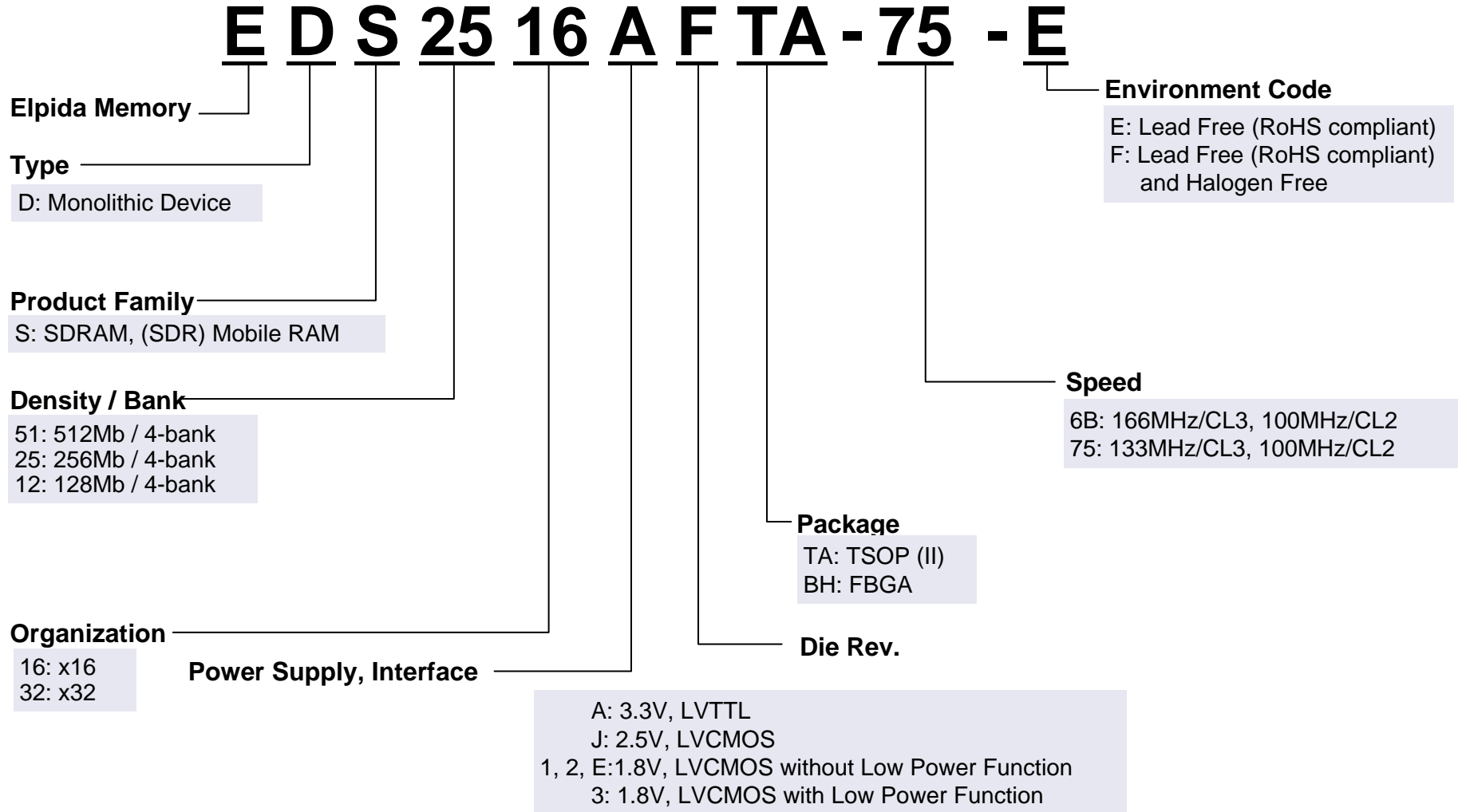

### XDR™

